



# THE ROYAL ENGINEERS JOURNAL

Vol LXXV

SEPTEMBER 1961

No 3

---

---

## CONTENTS

The Engineer-in-Chief's Address to the 1961 General Meeting of the Corps . . . . .	234
The Development of Engineer Equipment for the Army Brigadier H. A. T. Jarrett-Kerr . . . . .	242
Coopers Hill War Memorial 1959 Prize Essay . . . . . Major I. T. C. Wilson . . . . .	272
Hovercraft as Tank Carriers . . . . . Major A. J. D. Hughes . . . . .	279
The Present Status of the Small Power Reactor . . . . . Major A. A. T. Hiscock . . . . .	303
Joint Services Bomb Disposal . . . . . Major D. W. Townshend . . . . .	311
The R.E. Band . . . . . Captain K. V. Stewart . . . . .	325
A Closed File . . . . . Major T. C. White . . . . .	331
Correspondence, Memoirs, Book Reviews, Technical Notes . . . . .	333

PUBLISH

All c  
AGEN

INSTITUTION OF RE OFFICE COPY

DO NOT REMOVE

RS

# METROPOLITAN COLLEGE

Specialised Postal Coaching for the Army

## PRACTICAL AND WRITTEN Staff College and Promotion Examinations

Specially devised Postal Courses to provide adequate practice for written and oral examinations—All maps supplied—Complete Model Answers to all Tests—Expert guidance by experienced Army Tutors—Authoritative Study Notes—All Tuition conducted through the medium of the post—Air Mail to Officers overseas—Moderate fees payable by instalments.

\* \* \*

ALSO INTENSIVE COMMERCIAL TRAINING  
FOR EMPLOYMENT ON RETIREMENT

Write today for particulars and/or advice, stating examination or civilian career in which interested, to the Secretary, (M12), Metropolitan College, St. Albans



## ST. ALBANS.

Telephones  
ABERDEEN 33355      INVERNESS 1331

# WILLIAM TAWSE

LIMITED

CIVIL ENGINEERING AND  
PUBLIC WORKS CONTRACTORS

ANGUSFIELD · ABERDEEN  
and  
CARSE · INVERNESS

NEW FACTORY BUILDINGS at ROCHESTER  
for  
ELLIOTT-AUTOMATION LIMITED

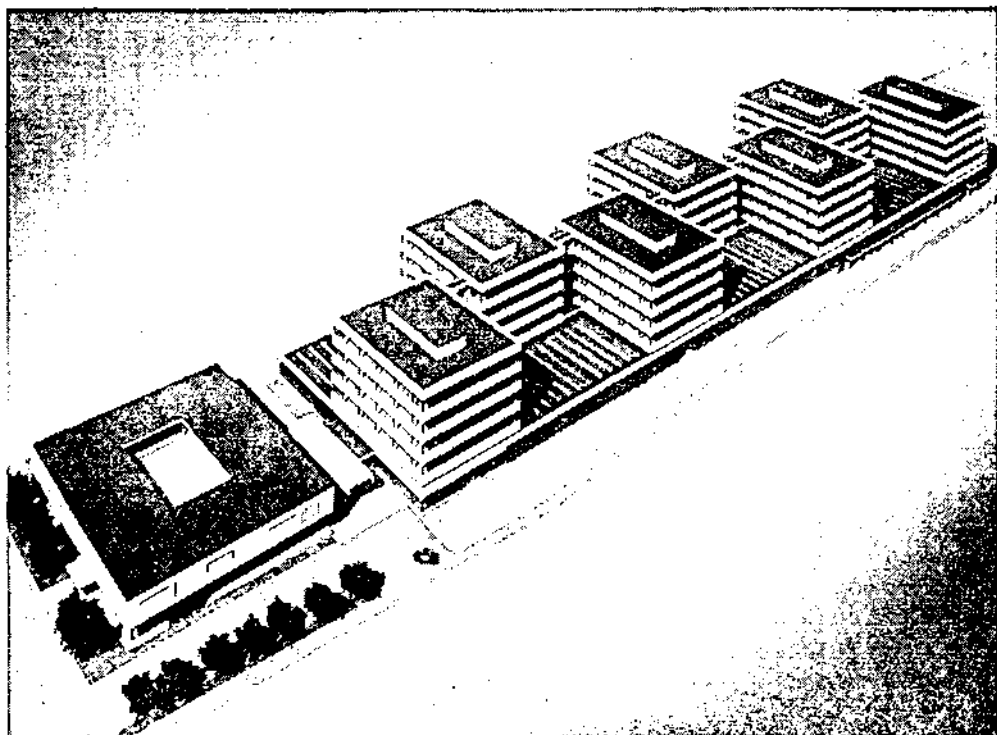

*Architects:*

Yorke, Rosenberg & Mardall

*Con. Structural Engineers:*

Felix J. Samuely & Partners

*Quantity Surveyors:*

Cyril Sweett & Partners

*Con. Mechanical Engineers:*

R. W. Gregory & Partners

*Builders*

**Trollope & Colls Ltd**

(Established 1778)

Trocoll House, 1 Noble Street, Gresham Street, E.C.2

---

---

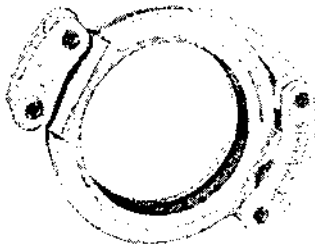
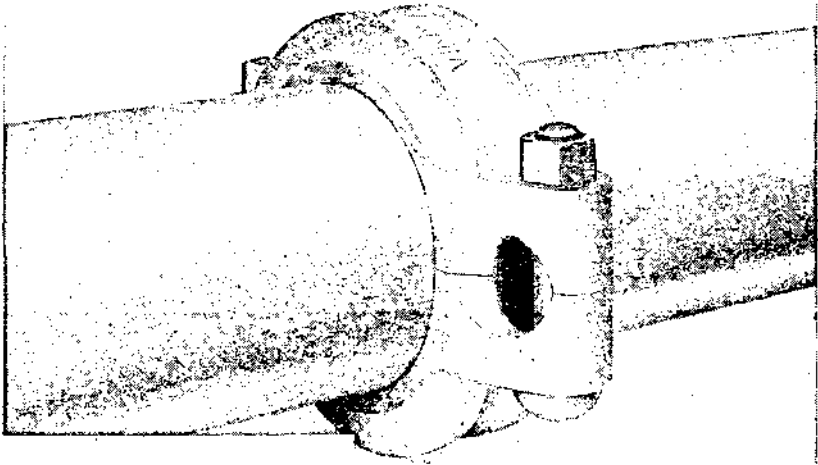

*Toggle joints, without nuts and bolts, can also be supplied in certain sizes.*

## VICTAULIC ALUMINIUM JOINTS

The Victaulic Company, leaders in flexible joints for forty years, manufacture light Victaulic joints in aluminium. These are die-cast from special alloys and have been perfected after exhaustive development and tests.

**Ease of Assembly.** The joint can be made rapidly on rough ground by unskilled labour. It couples pipes positively and cannot be assembled incorrectly.

**Flexibility.** Clearances between the joint housing and piping, combined with the gap between pipe-ends, permit an angular movement of the piping and make exact alignment unnecessary when installing.

**Expansion and Contraction.** The gap between pipe-ends allows the piping to expand or contract. This and the flexibility of the assembly reduce pipe-line stresses due to subsidence or settlement, and allow the pipe-line to follow the contour of the ground with a minimum of bends.

ILLUSTRATED LEAFLET AVAILABLE ON REQUEST

### THE VICTAULIC COMPANY LTD

Manufacturers of Victaulic Joints and Viking Johnson Couplings

8 GOUGH SQUARE, FLEET STREET, LONDON, E.C.4

Telephone: Fleet Street 8346

Registered Trade Marks 'VICTAULIC' and 'VIKING'

---

---

# THORNYCROFT

Designers and Builders  
of  
**MILITARY VEHICLES**  
for over 60 years

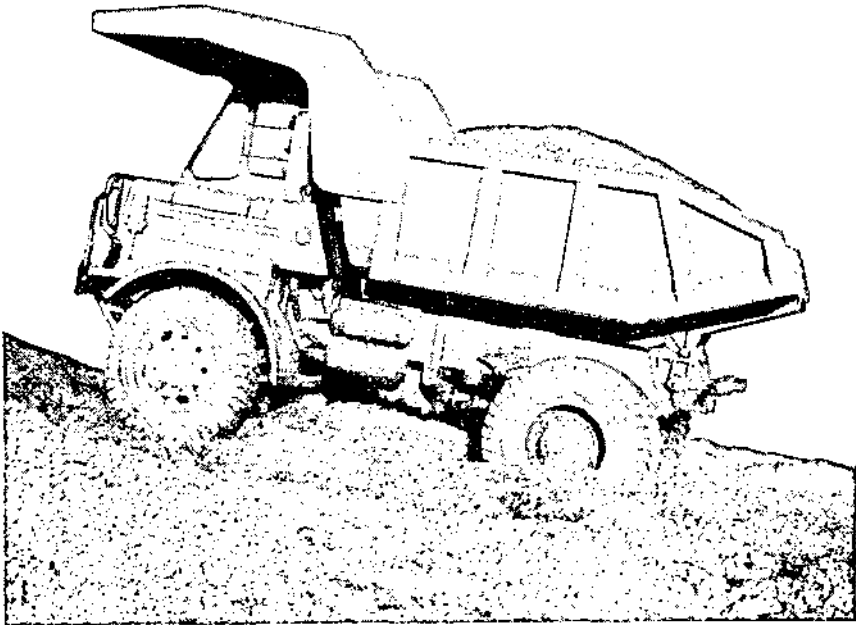

*Thornycroft 4 × 4 Dump Truck with 9 cu. yd. body*

---

**Thornycroft**  
**MULTI-FUEL ENGINES**  
available

---

TRANSPORT EQUIPMENT (THORNYCROFT) LIMITED  
BASINGSTOKE, HANTS

---

---

## You are welcome at No. 6 Pall Mall

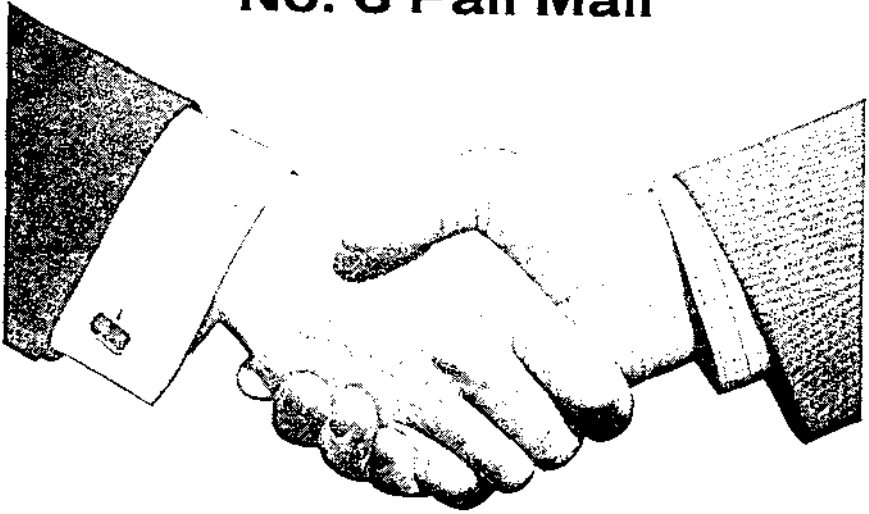

at **Cox's and King's** branch of Lloyds Bank, 6 Pall Mall, S.W.1 we have been officially appointed Army Agents for over two hundred years and Agents to the Royal Air Force since its inception. Of course you may bank where you please but the reason why so many officers open their personal accounts with us is that we have unrivalled experience in dealing with the

financial affairs of officers stationed at home or abroad.

We have departments specialising in general and kit insurance, in income tax, the purchase and sale of stocks and shares and the safe custody of valuables. This *full banking service* includes facilities for serving officers to cash their cheques at any branch of the Bank without prior arrangement.

An officer's banking transactions are confidential to him and his bank. Our position as Official Agents in no way affects this.

### LLOYDS BANK LIMITED

**COX'S & KING'S BRANCH, 6 PALL MALL, S.W.1**  
Telephone **WHitehall 7001**

Official Agents to the Army and Royal Air Force

# THE COUNCIL OF THE INSTITUTION OF ROYAL ENGINEERS

(Incorporated by Royal Charter, 27 February 1923)

Patron—HER MAJESTY THE QUEEN

## President

Major-General Sir A. Douglas Campbell, KBE, CB, DSO, MC, MA ... .. 1957

## Vice-Presidents

Brigadier A. G. Bonn, CBE, MC, MICE ... .. 1957

Major-General T. H. F. Foulkes, OBE, MA ... .. 1960

## Elected

Captain K. V. Stewart, BSc ... .. 1958

Brigadier P. N. M. Moore, DSO\*\*, MC, BA ... .. 1959

Colonel E. F. Kyte, OBE, MA, AMICE ... .. 1959

Colonel R. W. C. Smales, MA, AMICE ... .. 1959

Lieut-Colonel G. W. Kirkland, MBE, MICE, PIStruct.E,  
Minst.HE, Finst. Arb., MConsE ... .. 1959

Lieut-Colonel J. E. Weller, MC, MA ... .. 1959

Colonel H. C. G. Cartwright-Taylor, BA, AMICE ... .. 1960

Lieut-Colonel I. D. S. Brown, MC, BA ... .. 1960

Lieut-Colonel J. R. Cave-Browne, MC, BA ... .. 1960

Major-General D. C. T. Swan, CB, CBE ... .. 1960

Major G. B. Duffy, MC ... .. 1960

Lieut-Colonel R. H. Braybon, MBE, TD, RE (TA) ... .. 1960

Colonel C. W. Woods, MBE, MC, MA ... .. 1961

Lieut-Colonel A. H. Rodgers, MC, AMIMechE, RE (AER) ... .. 1961

## Ex-Officio

Brigadier A. P. Lavies, CBE, MA ... .. BGS, RE

Colonel A. G. Peart, OBE, BA ... .. AAG RE

Brigadier E. F. Parker, OBE, BA ... .. Comd SME

Brigadier L. J. Harris, CBE, MA, FRICS ... .. D Survey

Colonel M. B. Adams, BA, AMICE, C ... .. Col. (AQ) HQ, SME

Brigadier H. W. Kitson, CBE, MA ... .. Comd, Trg Bde, RE

Brigadier A. G. P. Leahy, OBE, BA ... .. Comd, Tn Centre RE

Brigadier R. B. Muir, CBE, BSc, MICE, AMIMechE, AMIEE,  
AMIStruct. E, MBIM ... .. Brig. "E" (Q Services)

## Corresponding Members

Lieut-Colonel P. H. G. Hamilton, BSc, ADMS, RNZE,  
*New Zealand Military Forces* ... .. 12 November 1960

Colonel C. Linsell, OBE, MC, *Union Defence Force, South Africa* ... .. 1 February 1956

Brigadier A. T. J. Bell, OBE, *Australian Military Forces* ... .. 15 August 1960

Colonel D. W. Cunningham, GM, CD, *Canadian Army* ... .. 2 September 1958

## Secretary and Editor RE Journal

Brigadier J. H. S. Lacey, CBE, BA ... .. 15 December 1958

## Bankers

Lloyds Bank, Ltd, Cox's and King's Branch, 6 Pall Mall, SW1

# THE ROYAL ENGINEERS JOURNAL

*Authors alone are responsible for the statements made and the opinions expressed in their papers*

VOL. LXXV

CONTENTS

SEPTEMBER, 1961

	PAGE
1. THE ENGINEER-IN-CHIEF'S ADDRESS TO THE 1961 GENERAL MEETING OF THE CORPS	234
2. THE DEVELOPMENT OF ENGINEER EQUIPMENT FOR THE ARMY. BY BRIGADIER H. A. T. JARRETT-KERR, OBE, BA ( <i>With Photographs and Plates</i> )	242
3. COOPERS HILL WAR MEMORIAL 1959 PRIZE ESSAY. BY MAJOR I. T. C. WILSON, MBE, MC, RE	272
4. HOVERCRAFT AS TANK CARRIERS. BY MAJOR A. J. D. HUGHES, RE. ( <i>With Photo- graph and Plates</i> )	279
5. THE PRESENT STATUS OF THE SMALL POWER REACTOR. BY MAJOR A. A. T. HISCOCK, BSC(ENG), RE	303
6. JOINT SERVICES BOMB DISPOSAL. BY MAJOR D. W. TOWNSHEND, RE	311
7. THE RE BAND. BY CAPTAIN K. V. STEWART, RE (SECRETARY, RE BAND)	325
8. A CLOSED FILE. BY MAJOR T. C. WHITE, RE	331
9. CORRESPONDENCE	333
THE QUEEN'S ENGINEERS	
REALISTIC TRAINING	
THE LATE BRIGADIER SIR C. F. CARSON, KI, CBE, MC	
10. MEMOIRS	335
BRIGADIER-GENERAL J. R. YOUNG, CB	335
BRIGADIER-GENERAL R. P. T. HAWKSLEY, CMG, DSO, DL, JP	335
BRIGADIER-GENERAL A. B. CAREY, CMG, DSO, OStJ	336
BRIGADIER L. MANTON, DSO, OBE	337
BRIGADIER J. STUART	338
COLONEL J. HODGART, MC, TD	340
COLONEL W. B. SYKES, CBE, TD, DL, JP	340
LIEUT-COLONEL R. H. DENNISS	342
MAJOR G. B. JOHNSON, OBE, FRES ( <i>With Photograph</i> )	342
11. BOOK REVIEWS	343
THE STORY OF THE FRENCH FOREIGN LEGION	M.C.A.H.
12. TECHNICAL NOTES	344
CIVIL ENGINEERING	
THE CONTRACT JOURNAL	
ENGINEERING JOURNAL OF CANADA	
THE MILITARY ENGINEER	



## The Engineer-in-Chief's Address to the 1961 General Meeting of the Corps

IN his address delivered to the Annual General Meeting of the Corps on 28 June 1961 Major-General T. H. F. Foulkes, OBE, the Engineer-in-Chief, reviewed the world-wide activities of the Corps. Amongst some of the points he covered were the following:—

### RUN DOWN OF THE REGULAR ARMY

The Army is still in a period of transition. During the last year the strength of the Corps has come down almost to its all-regular size and in the UK we are approaching our long-term regular order of battle.

A high level staff study of the future logistic realities of limited war, and other discussions, has led to a growing awareness of the scarcity of engineers in the all-regular army. The shortage of men in many RE units, particularly in BAOR and at home, is fully appreciated. The situation will eventually improve, but it may get worse before it gets better. The one and only remedy is to improve our recruiting figures.

### CIVILIANIZATION OF WORKS SERVICES

The civilianization of Works Services has been completed and a generous message of thanks was received from the Army Council last September acknowledging the great work of the Corps in this important field from the Army's earliest days. One hundred and five retired Sapper officers have been taken on by the new WD Works Organization and a large number of ex-RE clerks of works. Many other retired Sapper applicants are still being considered.

The Engineer Special Services Establishment, ESSE, came into being last September and through it we are still carrying a considerable peacetime responsibility for Works Services, mostly overseas. The high quality of ESSE personnel is most impressive. Many are working in difficult conditions. We can be very proud of these Sappers and they forcibly remind us that it is when conditions are at their worst that the Corps most excels and cannot be rivalled by anyone.

Attachments to civil firms and public bodies include some interesting and varied appointments and Treasury agreement has been obtained to reasonable allowances to Sapper officers employed by Dominion and Colonial Governments. An example of an outstanding appointment was the inclusion of Warrant Officer Class I F. W. James, RE, in the erection crew of a nuclear power plant recently built by the US Corps of Engineers in Greenland.

A policy is being adopted within the Corps of encouraging competence in civil, electrical and mechanical engineering. Our long courses are being

reshaped to approach the requirements of the chartered professional institutions and officers on successful completion of such Courses should be well on the way to qualifying for associate membership of the professional institution concerned.

#### UNIT ACTIVITIES AT HOME AND OVERSEAS

73 Field Squadron on Christmas Island has spent the last year mostly on the maintenance of installations, but a church, St George's, has been built near the port area. A reconnaissance of the Gilbert, Ellice and Phoenix Islands has been made on behalf of the Colonial Office to discover the feasibility of blasting gaps through coral reefs to provide passages for sizeable craft to these islands.

The RE support unit at Maralinga Range gives a good account of itself and relations with the Royal Australian Engineers are very cordial.

In the Far East a training area is being developed in North Borneo which has entailed the construction of roads, the building of camps and airstrips and the operation of a river L of C for heavy equipment. 54 Independent Field Squadron in Hong Kong has been engaged in garrison duties, flood relief work and the laying of under water pipelines. The Chinese Bomb Disposal Troop of 306 ESD continue to dispose of UXBs and the unit is also efficient and useful in field engineering duties generally.

Although the emergency in Malaya is officially over, small operations continue along the border with Thailand, and the Federation Government has a grand development programme for the country. Engineer work on roads, tracks, light aircraft strips and helicopter landing zones has been affording some admirable training to British, Malayan, Federation and Gurkha Sappers. The Base Engineer Group, Singapore, now embraces all RE units and detachments on the island.

After completing work on the Dharan depot for the Brigade of Gurkhas, the CRE (Works) disbanded last April. Lieut-Colonel H. W. Baldwin, OBE, RE, who received the Order of the Right Hand of the Gurkha for his services to Nepal, is now in charge of the Malacca project.

One of our remaining CsRE (Works) is responsible for building the Kahawa Cantonment in Kenya. 34 Independent Field Squadron forms part of the brigade group there.

The designation, Middle East Land Forces, now applies to troops south of the air/sea barrier including the Arabian Peninsula and East Africa. The Independent Troop based on Aden has had a busy year with road and track work, water supply and, temporary camps. The Works Detachment sent out to help the Air Ministry Works Department has been withdrawn, having finished its task and won high praise.

The troops in the area north of the air/sea barrier are now called Near East Land Forces. Our contribution, all based on Cyprus, includes an Independent Field Squadron, a Survey Engineer Regiment, and a Troop of a Port Operating Squadron. All these units have been busy on their various tasks, and the Chief Engineer is planning an ambitious exercise in North Africa in the autumn.

The Malta Fortress Squadron continues to deal with a number of unexploded bombs still being discovered on the island. It has also done some good training in Libya.

Having successfully repelled a number of attacks in previous years we have suffered a setback in Gibraltar, and it has been decided to reduce the engineer garrison from a Fortress Regiment of two Squadrons to only one Fortress Squadron. It is very sad to see this happen in a garrison where the Corps has such an historic and proud record but 1 Fortress Squadron, the direct descendant of the original unit of the Corps, survives in its original location.

Survey units have been particularly busy in North Malaya, Brunei, Kenya, Oman, Cyprus, Libya and at home. Their commitments to the Royal Air Force are always growing. One officer has been spending the season in the Arctic Circle and another on the Ross Ice Shelf.

By far the largest concentration of our field units is in Germany, where the tempo of collective training has continued to be somewhat too fast for the proper individual training of officers and other ranks, but steps are being taken to remedy this. Divisional Field Squadrons, after living with their Brigade Groups for the last few years, are to be united again as Divisional Engineers. It is hoped that they will soon be under the direct command and control of their own CsRE and this should help to improve the efficiency of their training and administration and enable them to take their part again as major units in the life of BAOR. As an example of international co-operation, the Divisional Engineers of 4 Division took part in a NATO exercise in Schleswig-Holstein when 4 Division, 4 Canadian Infantry Brigade Group and 16 Independent Parachute Brigade were opposed by a Danish Division and a German Panzer Grenadier Division.

59 Field Squadron formed part of the Battalion Group sent to the Southern Cameroons last June to enforce law and order at the time of the plebiscite, and they have now been relieved by a troop of 20 Field Squadron. Their work has ranged from camp construction to internal security patrolling. 160 Works Section RE was formed to help the WD Works Organization with camp construction and some individual military clerks of works were sent out at the request of that organization, who could not meet this particular commitment. The relationship between the Corps and the WDWO best suited to provide the engineer support needed for future operations of this type are being studied.

In the UK, despite all the efforts put into normal training, demonstrations and recruiting publicity, some interesting engineer work has been carried out by RE units which has included a permanent bridge for the Forestry Commission in Northumberland, various flood relief tasks, a fine heavy girder bridge across the River Avon at Bath, constructed by the Wessex Divisional Engineers (TA), and an exceptionally long heavy girder bridge over the Ouse at York with a clear span of 225 feet. Bomb disposal in the United Kingdom is a continuing commitment. There has been a reorganization in Transportation designed to make transportation units more adaptable to conditions of cold and limited war, and a RE Shallow Diving School has been set up at Marchwood.

#### REORGANIZATION OF THE RESERVE ARMY

The main structural change in the army at home has been the reorganization, first of the Territorial Army, and now of the Army Emergency Reserve.

In the new AER there is a clear separation between its two main parts. Category I, in which volunteers are liable for service without the issue of a proclamation, provides the units and the pools of individuals needed to make up the order of battle of the Regular Army for limited war. Category II furnishes those units and pools of individuals, required at home and overseas on general mobilization, complementary to the Territorial Army. As a result of this, we now have many fewer field and works units in the AER. The number of Transportation and Movement Control units has not been much reduced and Postal Units have actually increased. Though volunteering for Category I has so far, been fairly good, there is room for improvement in Category II.

The Territorial Army has been reorganized for its new roles which are, firstly, the support of the Regular Army in General War and, secondly, home defence in all its aspects. Although two TA Lieut-Colonels' commands have been lost, the appointments for Engineer Group Commanders have increased from five to seven. Most Corps Engineer Regiments and Divisional Engineers have been reduced to two field squadrons but many of the personnel of disbanded squadrons have transferred to surviving units.

The Reserve Army is an integral part of the British Army, which would be incomplete without it. This is particularly true in the case of specialist units which we cannot afford to maintain on the regular establishment in peacetime.

A number of Royal Artillery (TA) units have been converted to Royal Engineers, and some existing RE (TA) units have assimilated many Gunners from RA units which have ceased to exist. All the commanding officers of the units so affected have been written to personally by the E-in-C and the expressions of keenness and loyalty to the Corps contained in their replies have been very pleasant to read.

#### TRAINING

3 and 4 Training Regiments have been absorbed by 1 Training Regiment, which it is hoped will be established permanently at Guillemont Barracks, near Hawley Lake. The break with Gibraltar Barracks, Aldershot will be painful, but it is essential to locate our one remaining Training Regiment close to its training area.

At Chatham, Brompton and Kitchener Barracks are being modernized. Gordon Barracks is to be replaced by a new barracks to be built close to the training area north of the Medway at Chattenden, and new workshops are to be built to replace the RE Park. Trades training is to be grouped under the control of the appropriate SME School. The Plant, Roads and Airfield School has been resuscitated. Many distinguished civilian engineers were invited to see this year's RE demonstration and they were very impressed and indeed surprised with what they saw. It is hoped that many of the enthusiastic schoolboys and cadets who also attended will one day be attracted into the Corps.

The Chief Engineer, Northern Army Group, ran Exercise Makefast IX at Chatham last May where we were for the first time privileged to entertain and instruct at the SME more than one hundred engineer officers from West Germany, Holland, Belgium and British Forces in Germany. The foreign officers were most appreciative of the excellent arrangements made for them

and impressed by our facilities and our traditions, and we can pride ourselves on having contributed something of value to the NATO Alliance.

At present we have, proportionately more men under training than any other arm or service and, to cut down the large number of non-effectives, steps are being taken to reduce the time spent on basic training and to increase the time on higher and trades training. Priority is being given to the proper training and handling of recruits which is fundamental to the future of the Corps.

An Armoured Engineer Training Troop is being set up at Bovington this autumn to train the drivers, gunners and signallers for 26 Armoured Engineer Squadron in Germany. It will work in close contact with the Royal Armoured Corps.

A number of commendable adventure training enterprises have been undertaken by units, and several individual officers are upholding the Corps in a variety of ventures. As examples, Lieutenant R. Wyness flew to Canada in April to take part in an expedition on Devon Island. Lieutenant P. F. Fagan is to be a leader in the Cambridge University Geographical Society expedition to the Karakoram Mountains. Lieutenant R. E. Langford is to lead the Cambridge University Arctic expedition. Captain M. E. Nanson is training hard, and very scientifically, to be the first army Channel swimmer, in July. All commanding officers are encouraged to support such activities and to make the fullest use of our very able Warrant and NCOs in the absence of officers for such enterprises.

#### EQUIPMENT

The re-equipment programme is proceeding on the lines indicated last year. In spite of the familiar delays wheeled and crawler tractors, air-portable graders, mines and water supply equipment are all coming along, and the new ramped powered lighters, to replace our venerable Z-craft, are sliding down the slipway. By the beginning of next year sets of heavy floating bridge will be in service and BAOR should be getting to know the amphibious Gillois bridge. Development of the fixed assault bridge continues. The new AVRE and the bridgelayer will be coming into service next year, and it is hoped the new ARK will follow shortly. In order to give field sections the maximum machine power for minimum weight, trials of high-cycle electric equipment are in progress.

#### PERSONNEL MATTERS

Very little other rank redundancy now remains. Redundancy in the ranks of majors and captains has been covered by voluntary retirement; unhappily, however, a very few lieutenant-colonels, who are not volunteers, will have to be retired under compulsion.

In October last year nearly all the regimental sergeant majors of the Corps were gathered together for ten days spent at the Training Brigade, the SME, RE Records and the Junior Leader Regiment RE. The aims of this convention were to bring these very important men abreast of the changes that are taking place in the Corps, to make personal contact with them, to obtain the benefit of their experience and wisdom and to direct their efforts and influence to the achievement of the Corps' current aims.

Overshadowing everything else, however, is the problem of recruiting. We have not been obtaining all the men we need and the summer and autumn of 1960 were particularly lean times. Great efforts are being made to improve the situation. Lieut-Colonel R. L. Clutterbuck, OBE, RE has been placed on special duty to overhaul and supervise our recruiting methods. It will take time before some of our new measures can be effective, but it is gratifying to note that our intake improved considerably during the first quarter of this year. There is, however, a large deficiency to be made good and there is neither room nor reason for complacency. Recruiting will remain our primary problem for the next two or three years. The best service anyone can do for the Corps just now is to "get a recruit", or plenty of them if possible.

One of our requirements is to make the Corps better known to the public fifteen years after a major war, and to make the names Sappers, Royal Engineers and RE once more household words. In this connexion the title "Field Engineer" has been changed to "Combat Engineer". The expression "Field Engineer" is generally unintelligible to the modern young civilian and it has little appeal to his martial instincts. In these days of specialized engineering it might well be taken to mean a "mechanized farmer". The expressions "combat", "combat zone" and "combat development" are already part of our military vocabulary and generally understood by the public. There should, therefore, be no doubt about the meaning of the title "Combat Engineer" or any reluctance to accept this change.

The quality of the boys becoming apprentices at Chepstow and those entering the Junior Leader Regiment RE at Dover, remains high and, although we may be accused of being over-selective, we are approaching our Corps ceiling. Anyone who heard our Junior Leaders shouting for their boxers when they beat the Royal Armoured Corps in the Army Final by 21 points to 20, will know what a force these young soldiers are going to become.

We also want more young regular officers, and Sandhurst can never provide the numbers we need. The autumn batch was exceptionally small, but three-quarters of them were under officers, and numbers in future look like improving somewhat. It is most important that we should supplement these normal Sandhurst entrants by more from the universities and other sources. We have already had three university entrants this year, compared with only four in the last six years. There is, therefore, some hope that the situation may be improving. Much of course depends on the reputation and performance of our own YO's at Cambridge. Lieut-Colonel W. G. H. Beach, MBE, MC, RE, now commanding the Cambridge University OTC, has been charged by the DGMT with looking after the interests of the Army at the University, as well as keeping an eye on the YOs in residence, two most important commitments.

The Corps booklet *Follow the Sapper*, describing the life of the RE officer, has run into a series of extraordinary difficulties but we expect it from the printers next month, and I hope it will be very widely circulated.

A number of rather diffident letters from parents or relations of boys who want commissions in the Corps have been received by the E-in-C and he would like it known that he welcomes all such inquiries and is never too busy, when in the UK, to deal with them personally.

## CORPS MATTERS

The Instruction on Officers' Dress, mentioned last year, was issued early in June, and is to be fully effective by 1 January 1963. It will help to ensure uniformity.

The War Office Establishment Committee has agreed to the setting up of a small Corps HQ Staff. The chief posts so covered are the Treasurer RE Corps Funds Account, a head librarian, a curator of the RE Museum and a technical adviser to the Board of Control of *The Sapper*. This will relieve some hard-worked serving officers of the extra duties they have had to do in the past and will undoubtedly make for great efficiency. It will also save us money.

Lieut-Colonel Jim Chatterton, who has been Secretary of the HQ Mess for the past fourteen years, retired on 1 June last. A presentation was made to him on behalf of the Officers of the Corps, and we also made one to Mrs Chatterton in gratitude for her beautiful flower arrangements in the mess over many years. The mess has done us great credit during their time, and the Officers of the Corps will wish them well in their retirement.

## CONCLUSION

The E-in-C stated that during the last year he had received much help and hospitality during his visits to Gibraltar, the Far East, Canada and the United States for which he was very grateful. With our Canadian cousins we all knew we had a great deal in common, but the Corps in general might not realize how strong an affinity existed, both in thought and practice, with the United States Corps of Engineers, or how generously they treated all Royal Engineers in their country. For this reason he was always anxious to repay some of the hospitality we owe them and he hoped that all Sappers would ensure that any American officer of that very able and courteous Corps who found himself in this country was well looked after.

During the year we had continued to hold our own in all aspects of military life. On the twenty-third course at the Joint Services Staff College, no less than one-third of the Army students were Sappers. In the Staff College entrance examination we had obtained two competitive vacancies and forty-three other RE officers passed; much better figures than for the two previous years, though a disappointingly small number had been selected. In future the Staff College Course would begin with three months at the Royal Military College of Science, Shrivenham, an innovation which could hardly be to the disadvantage of Sappers in relation to those who had hitherto lived unscathed by science, and a clear sign of the irresistible trend towards recognition of the need for scientific ability in every man of proper education in this age of machine power and instrumentation.

Sapper Boys of 577 Field Squadron RE (TA) had passed first of those who took the entrance examination into Sandhurst. Sapper R. A. G. Baldwin was the first boy soldier to win the Duke of Edinburgh's Award, and he had been followed last month by Sappers P.A. Rees and W. J. Quayle. Other individual distinctions had been gained, but it was the collective performance of the Corps that mattered most and it was gratifying to see the enormous efforts that had been made by all ranks to do the Corps and themselves credit in every way.

In his address last year, the E-in-C said, he had laboured the concept of the "military engineer", but no concepts were any use in themselves without excellence of performance, and so the theme now offered the Corps was "excellence", a standard which was within the reach of every Sapper who took enough trouble.

The E-in-C concluded by saying that in Corps affairs there could be no finality. Whilst he was in the War Office he saw himself as the pilot of a ship sailing through rather turbulent and shallow waters in which the winds and tides were strong and variable. Before this part of the voyage began some two years ago many would remember that there was an open debate on the proper course to steer. Although he was still highly receptive to information and opinions on shoals and currents and meteorological forecasts (whether they came from outside or from the observations of the crew or those passengers, now retired, who had previous experience of this sort of voyage), and was willing to adjust his course accordingly, he had no intention of swinging the wheel about. Anyone who felt like shouting "Shipwreck" should remember what they did to Jonah. His main preoccupation was with the two rocky shores, to port and starboard, called Technical Incompetence and Military Ineffectiveness. War and cold war winds had blown us rather closer than he liked to the rocks of Technical Incompetence and he was steering well clear of them. In the meantime the crew, while keeping a look-out, would do well to leave such worrying as there might be to the pilot, get on with their jobs and enjoy the exhilarating voyage towards more open waters.



# The Development of Engineer Equipment for the Army

By BRIGADIER H. A. T. JARRETT-KERR, OBE, BA

Deputy Director, Military Engineering Experimental Establishment

*Paper to be discussed at the first joint professional meeting of the Institution of Structural Engineers and the Institution of Royal Engineers, which will be held at the Institution of Structural Engineers, Thursday, 9 November 1961.*

## SYNOPSIS

THE development of equipment for the Royal Engineers is influenced by many factors which do not affect commercial plant and civil engineering equipment to the same extent or in the same way. The paper considers these factors, and describes the phases through which development passes.

The majority of RE equipment is developed by the Military Engineering Experimental Establishment (MEXE). The facilities there for research, testing, and development are described. Examples are given of various recent developments in the fields of bridging, structures, construction plant, road and airfield materials, electrical and mechanical equipment, and petroleum storage and distribution equipment.

## INTRODUCTION

The Corps of Royal Engineers has a traditional role of increasing and maintaining the mobility of the Army, by overcoming obstacles of all kinds, by the construction and maintenance of bridges, roads, airfields and railways, and by operating ports and inland water transport. For these, and for the numerous other tasks they have to fulfil, a multiplicity of plant and equipment is needed, much of which must be developed specially to meet the particular requirements of the field units of the Corps. Even when basically civilian plant can be used, it often has to be modified, and it certainly needs to be tested before large numbers can be purchased.

This paper describes some of the development and testing required, and the means by which they are carried out. Most of this work is done by the Military Engineering Experimental Establishment (MEXE). In general terms, MEXE is responsible for all engineer equipment and plant, other than fighting and load-carrying vehicles. The paper inevitably includes descriptions of some of the facilities there, and the author is indebted to his colleagues at MEXE who have furnished much of the detailed information.

## USE OF COMMERCIAL EQUIPMENT

The question is often asked, why should military engineers require anything different from civil engineers? This is a fair question from any taxpayer who is conscious of the great cost of war material, and from those who have to sell the products of industry, at mass-production prices. It is, however, not always appreciated what a large amount of commercial equipment

is in fact used, not only by the Royal Engineers, but also by the rest of the Army. It is indeed the policy of the Army Council to use standard commercial equipment where at all possible, for the sake of economy in development and production. For example, the vast majority of Army load-carrying vehicles are based on standard commercial chassis and engines. In the same way the bulk of engineer earth-moving plant is of standard commercial manufacture.

There are, however, certain requirements of the military engineer that make commercial equipment unsuitable, in some fields. This means either that there must be some modifications, often of quite a major kind, or that special designs must be made. This is inevitable if the Army is to be equipped to carry out its tasks; just as the gunner must have guns and ammunition, or guided missiles, for which there is no commercial requirement, so the Sapper must have some specialist tools. It is therefore worth pausing to consider in a general way some of the factors that make the requirements of the military engineer different from his civilian counterpart.

#### MILITARY ENGINEERING FACTORS

In considering the factors that influence the development of military engineering equipment it is necessary to remember the world-wide nature of the tasks for which the Army must be prepared; and while civilian engineering organizations such as contractors or oil companies may have tasks in many different countries and climates, they are not so ubiquitous as the military engineer must be—not for nothing is the motto of the Corps of Royal Engineers "*Ubique*". A civilian engineer can usually plan his task in great detail, to ensure the maximum economy of labour and materials, and the fullest use of capital facilities, such as plant; in so doing he takes into account the climatic and other conditions of the country that affect his task, or his designs. But the Sapper must have ready-made equipment and plant to suit any likely task, anywhere, and under almost any conditions.

##### *Time*

In war it is the time factor that has the greatest effect on the development of engineer equipment: this is true not only because there is no time to plan or design structures or plant for a particular operation, but also because the actual execution of an engineering task must be extremely rapid. Time is at a premium as almost never before, particularly in the limited war role of the small regular Army, with the ever present nuclear threat. If the Army is to act as a fire brigade ready to go anywhere at short notice, there is no time to load up ships, and the essential equipment must be flown with the troops to the trouble spot. Thus the time factor leads to another requirement, air-transportability; and since the engineers have tasks that must be performed almost at the outset of any operation the equipment to do them must be air-transportable, and consequently small and light.

Under a nuclear threat, dispersion and the employment of highly mobile battle groups help to avoid presenting worthwhile nuclear targets to the enemy. This high mobility implies that there will be less time than ever for the usual engineer tasks of bridge-building, operation of ferries, preparation of routes, and so forth. Here the time factor has a more direct influence on design, because equipment must not only get to the site quickly, but operate or be constructed quickly when there. To satisfy these requirements it must be light, because by the very nature of things heavy and bulky material cannot be handled fast without great power, or numbers of men.

*Lightness*

Thus airportability and speed, which are the products of the time factor in military operations, demand lightness as an essential military requirement. This involves the maximum use of light-weight materials, of high stresses in structural members, of high pressures in hydraulic mechanisms, of high speeds in rotating machinery, and of other means of reducing weight, even at the expense of reducing factors of safety and of shortening life. This is not unreasonable when account is taken of the many other hazards of war. But the need for lightness conflicts with reliability and robustness, which are clearly important requisites in military equipment, as much as in the civil field. This conflict can only be resolved by far more careful and rigorous testing than can ever be done commercially; a theme which will recur later, because it is the background to much of the work at MEXE.

There is, however, another dilemma that results from the need for lightness; it is the choice between the light machine that can be got to the job quickly and the heavier machine that can do the job quickly, but may be more difficult to transport. Here there must be a compromise. In an airborne operation, the largest machine must be chosen that will go into the transport plane, even if it is a machine with restricted output; and for the more sustained engineer operations the heavier plant must be brought up with the sea or land-borne "tail", if there is one. The former may have to be a "military special"; the latter will probably be standard commercial plant.

*Prefabrication*

A further effect of the time factor is to reduce to a minimum the number of mechanical or structural operations that can be carried out in the field, such as the fitting together of components, the use of rivets, or of nuts and bolts. Consequently where constructional equipment is concerned, such as for bridging or other field structures, the maximum use must be made of factory prefabrication, and of pre-assembly in a stores depot, to make assembly in the field easy. It was, for example, prefabrication, above all other characteristics, that made the Bailey bridge the success it was. It is no new method, and has its application in the civilian field, in the construction of temporary housing ("prefabs"), of schools, of ships' hulls and super-structures, to give a few examples. But in military engineer equipment, particularly bridging, prefabrication has been developed to a fine art, under the far-seeing direction of Sir Donald Bailey.

*Mechanization*

One means by which speed can be attained is by the use of mechanical aids, or even by the complete mechanization of an engineer task. This process also saves manpower, and helps to reduce the exposure of men to a minimum. The latter is a purely military requirement that has always applied to tasks under enemy fire, but now applies with even greater force to tasks under the threat of heat flash and radiation from nuclear weapons. The saving of manpower, however, is of great importance, especially in the small regular Army. In the civil engineering field the capital cost of expensive mechanical equipment, the need to reduce idle time to a minimum, and the availability of cheap labour in certain parts of the world introduce factors that do not affect military engineering to the same extent. If military engineers are to be employed to the best advantage their manpower must control as much machine power as possible.

Nevertheless, whether electric, hydraulic, or purely mechanical means are employed, mechanization does lead to complexity, with its attendant troubles of unreliability, increased maintenance, and more specialized training. This somewhat offsets the saving in manpower, but must be accepted, and reduced to a minimum by careful design and very thorough testing.

#### *Factors of Safety*

If design and testing are exploited fully it is possible to reduce factors of safety, and to design for a limited life, particularly in the case of structural members. It can be argued that there are so many other hazards in war that it is reasonable to accept a higher risk of failure from overloading or from structural fatigue than in peace-time. This is true, to a certain extent, but the argument can be carried too far, because the risk must depend on the importance of the equipment to the military operation. So a proper sense of proportion must be kept.

To give an example in the electrical field, it is possible in designing equipment for use in the open to insure against electrical shock by providing earth leakage monitoring systems; but these require additional cores in cables, and additional pins in plugs, with increased weight and complexity; and the extra safety obtained can be regarded as over-insurance, when other hazards are taken into account.

In a prefabricated welded structure, when the mode of failure cannot always be accurately predicted, tests by increasing loads to the point of destruction can reveal the true weakest point, and the load at failure; thus the working stress can be raised to a higher level, or in other words the factor of safety can be reduced, because it has to cover a smaller factor of ignorance. Furthermore if a structure such as a military bridge is unlikely to have more than a certain amount of traffic on it; and if the fatigue life has been accurately found by tests that simulate the load conditions; then it is possible to predict the life at various stress levels and to allow higher stresses.

There is another military aspect that allows fairly low factors of safety, in the case of bridging; the traffic crossing the bridge can be fairly closely controlled. Such control can be exercised either by governing the minimum spacing between vehicles (the standard distance for military vehicles crossing a bridge is 100 feet, nose to tail), or in some cases by only allowing them to cross singly. Furthermore the design of specialist vehicles can be regulated to conform with the military bridge classification system. Thus the loads are much more accurately known than is often the case for a civilian bridge.

#### *Mass Production*

Mass production methods, on the flow-line principle, are a primary means of reducing cost. Development with this factor in mind is therefore as essential for military equipment as for civil. But there are some fields of civil engineering where special purpose design is adopted, such as bridges and buildings; whereas in corresponding military fields the large numbers required demand the fullest application of mass production methods. As an instance of this, in World War II over 200 miles of Bailey bridge were produced; and in the early days the closest collaboration was necessary between the development and production teams to ensure that each component was suitable for mass production. However, large numbers are not required for all RE equipments, and it is therefore important to keep their

cost down by the maximum use of components that are in mass production for civil use. Thus it is this factor that influences most the general principles of development of RE equipment and plant namely:—

- (a) As far as possible standard commercial equipment shall be used;
- (b) only if the limitations of standard equipment cannot be accepted, and if the numbers required justify it, should a "military special" be developed; and
- (c) if a "military special" is essential, the design must be based on the maximum standardization of components.

#### RESPONSIBILITIES OF A RESEARCH AND DEVELOPMENT ESTABLISHMENT

The primary responsibility of a research and development establishment such as MEXE is, of course, to develop equipment for the Army in accordance with requirements clearly stated by the War Office. However, although "necessity is the mother of invention", a new idea does not always spring from the statement of a need. Ingenuity and inventiveness cannot be served up on a plate, to order, but grows best in a congenial atmosphere, where research and "forward thinking" are fully encouraged. MEXE for example covers many fields of engineering, and in each field there are civilian technical experts, with a small leavening of RE officers, who are continuously on the look out for new developments in their field. In considering the possible military applications of such developments their minds must range widely over the subject, and this may stimulate entirely new ideas. Fruitful military development can thus be initiated, even without any clearly stated requirement in the first place by the War Office.

In the past, much valuable development has been initiated by RE officers, with little official encouragement, using the resources of their own private workshops. How much more valuable it is, therefore for such officers to apply their inventiveness alongside civilian inventors and designers in the atmosphere of an establishment like MEXE, with its extensive technical resources! But inventiveness is not all that matters: much technical development requires continuity and long hard work, with many disappointments and apparently fruitless efforts, in the gaining of knowledge and experience that can bear fruit later. It is therefore important to keep the right balance, not only, for continuity, between the civilian and military staff, but also between the different types of work on which they are engaged.

At MEXE the work can be divided broadly into the following:—

- (a) Fundamental research, and trying out new techniques in materials or construction, to assess their possible applications to military engineering developments;
- (b) gaining knowledge of civilian technical advances in particular engineering fields, to assess their value, and to be in a position to advise the War Office on problems arising in those fields;
- (c) development of particular items of equipment in accordance with clearly stated needs; this includes improvements to, and new versions of existing equipment;
- (d) testing of commercial equipment and plant, with a view to acceptance or modification for military use;
- (e) testing and research in aid of particular developments, or to solve problems that arise in them.

Before describing some of this work in selected fields, an outline will

now be given of the phases through which development passes before the introduction of a new equipment into the service.

#### DEVELOPMENT PHASES

It would not be appropriate in this paper to describe the organization and full procedure within the War Office for the development of Royal Engineer equipment. It is sufficient to note, in broad terms, that the Engineer-in-Chief (representing the users) says what is wanted; then under the Master-General of the Ordnance the Director of Royal Engineer Equipment is the authority who passes the requirement to the development establishment (MEXE), progresses the development, approves the equipment, after acceptance by the users, as being technically suitable for introduction into the service, and finally arranges for its production.

The whole process of development is governed by careful rules that have been formulated as the result of experience over the years. Their main purpose is to avoid wastage of money and effort, under the vigilant eyes of the Treasury and the Public Accounts Committee, and to ensure that the Army gets what it needs and can afford. But the consequence is that the process is lengthy: figures have been published of as much as eight or ten years between the statement of the requirement and the time when the equipment is in service. These are very long times, and indeed every effort is made to reduce them, often with marked success. However, some delays are unavoidable if risks of abortive work are not to be taken, if proper thought is to be given at each stage, and if adequate trials are to be carried out.

One danger of a long time-scale of development is that the requirement may change before the equipment is produced, and effort may consequently be wasted. This danger is especially present when the future form of warfare is conjectural, because opinions may vary on what the effects are likely to be on the equipment required. However, this is offset to a certain extent by taking careful thought at each stage of development, even at the cost of lengthening the process, so that at any time a halt can be called or the direction altered before becoming committed to the next phase. Furthermore, any development, even if apparently abortive, adds to knowledge and experience, and contributes to efficiency and speed of the next development of similar form. An example of this can be given from the author's experience during the war, when he was put to work on the design of a pontoon bridge consisting of box girders, with limited articulation between rafts, to provide a degree of continuity at the joints. The calculations were somewhat complicated, and Professor Southwell (now Sir Richard Southwell), who was a member of the Structural Engineering Committee of the Scientific Advisory Council, suggested the use of the method of successive relaxation of constraints. He sent down two research students from Oxford University, who worked out the method of applying the system to pontoon bridges. When later it was decided that the Bailey bridge could be put on pontoons, and that the box girder type would not be worth proceeding with, the method of calculation developed was able to be applied without delay to the Bailey pontoon bridge, as described in Vol 1 of *The Civil Engineer in War* (article by Bailey, Foulkes, and Digby-Smith).

Risks can, of course, be taken in war-time, when greater effort and funds are available, with a great contrast in the time scale of development. To quote an example from experience, it only took one year from the first acceptance

of Sir Donald Bailey's concept to the time when the first Bailey bridge came off the production line! This development period included detailed design, manufacture, and testing of sample panels; full load testing of a bridge; launching trials by Sappers; and finally the setting up of production lines, with all that was entailed in obtaining high tensile rolled steel sections, and the manufacture of jigs, gauges, and proof testing rigs.

The design phases in peace-time are similar to those in war, but take longer for the reasons already given; and it is of interest to outline briefly what they are:—

(a) *Assessment of the Requirement.* Clearly the requirement must be stated unequivocally. However it is not always possible to do so without some idea of what is technically feasible. Therefore at an early stage the designers and users have to make an assessment of the problem—of the tasks to be performed by the equipment, and of the ways in which the requirement might be met. The assessment may show the need for one or more designs to be worked out in great detail, in design studies.

(b) *Design Study.* As soon as the requirement is clear, and a line of approach has been agreed, or a concept assessed, a more detailed paper study is put in hand. This is done either at MEXE, or through extra-mural contract by a firm of consulting engineers or manufacturers, under the direction of MEXE. At the same time it may be necessary to prepare "mock-ups" for showing lay-outs, or to make and test a rig to prove the technical feasibility of some aspect of the proposed design.

(c) *Design and Manufacture of Prototypes.* When the design study or studies have been examined, and the implications of cost and development effort have been worked out, financial authority can now be obtained. Detailed design work is then put in hand, either at MEXE or with a contractor. If the development is in a new and untried field, the initial pilot model may be manufactured in MEXE workshops, and given preliminary tests before prototype designs are completed and manufactured.

(d) *Trials of Prototypes.* Prototypes are required for full technical evaluation in development trials at MEXE, or elsewhere under the auspices of MEXE, such as cold weather starting trials of engine-driven equipments, in a cold chamber, or cross-country trials, at the Fighting Vehicles Research and Development Establishment (FVRDE) at Chobham. Prototypes are also required for evaluation by the users; this is done in the first instance at a school, such as the School of Military Engineering; then further models are usually ordered for world-wide "troop trials", in different climatic and operating conditions. Modifications may well be proved necessary in all these trials, and these of course take time to evaluate, work out, and apply to the equipments.

(e) *Acceptance and Approval.* When as the result of troop trials the user has accepted that the equipment is satisfactory, and when all technical trials have been completed, the equipment is finally approved as suitable for introduction into the service.

These phases have been given in general outline only, and it will readily be appreciated that there are many variations, according to the type of equipment. For example some of the earlier phases do not apply to commercial equipment or to ideas that have originated within MEXE; but the later phases are just as important, to ensure that the Army gets what it wants, and that adequate trials are carried out before large numbers are ordered.

Furthermore, there are several facets that have not shown up in this outline, such as the stages at which nomenclature is settled, cataloguing and scaling for spares are carried out, and production planning is initiated: these are outside the scope of this paper.

However, there is one important thread that runs right through the development phases, and that is the aim of smooth, rapid, and efficient transition from development to production. This is not peculiar to military development. Anyone with experience of production knows the teething troubles that arise when an article goes out of the hands of the developers into the hands of those responsible for production: then when the sales representatives and the customers get hold of it, and complaints start coming in, the troubles really start! The solution to this problem is to insist on adequate and continuous liaison at all phases of development between all those responsible. The development, production, inspection, maintenance, store-holding and distributing authorities must form a well-knit team. It is probably easier to do this in a service organization than in a civilian firm, especially as the "customers" can be brought in too, being part of the same organization. No system is perfect, but from experience of many years, as a design officer, as a user, and as a cog in the development and production machine, the author is of the opinion that the system for RE equipment is as good as, if not better than any.

#### BRIDGING

*Historical.* It is appropriate that a description of some of the particular aspects of the development of engineer equipment should start with military bridging, because MEXE was founded mainly on the Experimental Bridging Establishment (EBE). In World War I there was at Christchurch an Experimental Bridging Company, which was largely civilianized after that war, and became the EBE, under a distinguished Sapper Officer, Major Martel, later Lieut-General Sir Giffard le Q. Martel. During World War II the EBE expanded considerably, and in 1946 the small Experimental Demolition Establishment and the Experimental Tunnelling Establishment were joined with the EBE to form MEXE. Thus bridging was the stem on to which the rest was grafted.

There was always a need for light quickly erected bridges, and this led between the wars to the development of the small box girder bridge and the folding boat equipment. For the former in particular the value of welding was appreciated at a very early stage. Martel's original box girder bridge was rivetted, but the later developments were welded, and a lot of lessons had to be learned, in co-operation with manufacturers, and with various welding firms, such as Murex. In fact the work of EBE at that time did much to promote the use of welding in structures, and to ensure the introduction of adequate control of welding procedures.

It was experience of the manufacture of box girders, the difficulties of avoiding distortion, and of accurately drilling the holes for the connecting dogs, that led Mr (now Sir Donald) Bailey to suggest the panel construction that was the basis of the Bailey bridge. This simplified the manufacturing problems by reducing them to one plane, instead of a three-dimensional box, and it enabled pins to be used instead of the "dogs", which had proved difficult to make. That story has been fully told elsewhere (eg *Civil Engineer in War*, Vol I), but it is cited here to illustrate the constant need for close



association with manufacturers. The author has a vivid memory of a visit in 1940 to the factory of Sir William Arrol and Company in Glasgow, when he was thoroughly slated by the Managing Director (the late Mr John Thomson), who was then trying to manufacture a box girder with very difficult machining problems. It would never have been possible to have manufactured such box girder bridges in the enormous quantities that were required of Bailey bridges: the total production of Bailey panels during the war was just under 700,000!

It is not proposed to describe the history of bridging development in further detail, since it has been fully given up to the end of 1946 in two papers read before the Institution of Structural Engineers, by Colonel (now Brigadier, retired) S. G. Galpin in February, 1944, and by Lieut-Colonel (now Brigadier, retired) S. A. Stewart in November, 1946.

*Loads.* One of the biggest problems that have had to be contended with over the years has been the increase of military loads. In 1936 the heaviest tank was about 18 tons, but by the time the Infantry tank was produced in 1939 it has reached 24 tons, and it later rose to 26 tons. By 1940 the new Churchill was 40 tons. Since the war even heavier tanks have been produced, culminating with the Conqueror at around 70 tons! To compete in the race for supremacy there were developed a succession of bridges, and modified versions of earlier bridges. For example, while the current heavy girder bridge (HGB) was being developed it was necessary to use as much as possible of the stocks of Bailey bridge, by widening it to form first a standard widened Bailey bridge, then the extra widened Bailey bridge; each of these had pontoon versions, similar to the Bailey pontoon bridge. It is to be hoped that the HGB will be the heaviest; and indeed there is some likelihood that it will be so, because the need for mobility, already discussed, is likely to be a bigger factor than weight of armour and armament in the design of tanks.

*Recent developments.* It is not possible, for security reasons, to give a comprehensive description of all the most recent bridges to be developed, but the following is an outline of some:—

(a) *Heavy Girder Bridge (HGB).* This is a panel bridge of the same type as the Bailey, with panels and cross girders made of high tensile structural steel, the panels being larger and heavier. The roadway is 18 ft 10-in wide, suitable for two-way traffic, and decked with welded light alloy deck sections. It will take the heaviest military loads—for example, in single storey construction, with chord reinforcements, it will take tank transporters over 187 ft 6-in span. It was designed to be built by crane, and will provide replacement bridges in the communication zone.

(b) *Heavy Ferry.* This is a free-ranging raft, made up of light alloy pontoons: four identical main pontoons each form half the roadway; power-operated ramps are hinged to one end of each main pontoon; and on the outside of each is a buoyancy pontoon and a propulsion pontoon. The four propulsion pontoons, at the corners of the raft, each have a Gill propulsion unit, which takes in water through an intake in the bottom, and discharges it in as nearly as horizontal stream as possible through outlet vanes, at low velocity and large volume. Both inlet and outlet are flush with the bottom, and the outlet vanes can be rotated through 360 degrees about a vertical axis, thus providing a directional flow to propel the ferry. The pontoons can be rapidly launched, and connected together in the water by link mechanisms, to form a ferry suitable for the heaviest tanks.

(c) *Centurion Bridgelayer*. This is a light alloy bridge, carried inverted on top of a special Centurion tank chassis, and launched hydraulically over the front, turning over through 180 degrees in the process, to span a 45 ft gap. It consists of two box type girders, separated by a gap that can be decked by hand after launching; this may be required for wheeled vehicles, after the initial crossing by the tanks for which the bridge was designed. It can be laid as an assault bridge in a couple of minutes, and is suitable to accompany an armoured battle group.

(d) *Light Assault Floating Bridge (LAFB)*. This is a continuous through girder panel bridge, supported on light alloy bi-partite pontoons. It is designed for rapid construction, to take divisional transport (Class 30). The panels of the stiffening girder are of high tensile structural steel, and the pontoon decking and cross girders are of light alloy. The pontoon piers are spaced at 12 ft 6-in centres, and occupy approximately half the waterway; at the shore ends four pontoon piers are grouped close together to provide the additional buoyancy to support the offshore ends of the landing bays, which are 27 ft long. The girders of the landing bay are connected to the fully floating section by an articulating joint which is stiff under load, but automatically takes up for a variation in height of banks, and for changes in water level.

This was the first bridge to employ the "assembly line" technique in construction, with a high degree of pre-assembly, and with continuity of movement forward from a marshalling harbour to the final assembly in the river. This made it the fastest bridge of its class to be built. The same principle has been adopted in the latest pontoon bridge, the heavy assault floating bridge.

*Bridge Classification*. An important development since World War II has been the introduction of a system of load classification of military bridges and vehicles, which has been adopted as a standard agreement by all NATO allies. The principle is the same as that adopted by the British Army during the war; vehicles and bridges carry classification numbers, and a vehicle cannot cross a bridge bearing a lower number. But the new system is more extensive and less empirical than the one it replaced. It is based on a series of typical tracked and wheeled vehicles, the class number being derived from the weight (in short tons) of the typical tracked vehicle of that class. The wheeled vehicle in each class is heavier than the tracked vehicle, to compensate for the fact that it is not such a concentrated load. Maximum axle and wheel loads are specified, and the minimum spacing between vehicles in single line traffic is 100 ft.

A full description of the system, with calculations of bending moments and shears for different spans, is given in Stanag 2021, which has been widely circulated by national authorities, and is also contained in military engineering textbooks. It is not therefore proposed to give further details here. But all military bridges are now designed to conform with one of these load classes.

*Design factors*. Most of the design factors that influence the development of military bridges have already been mentioned. In particular speed of construction and lightness of weight are of primary importance, apart from the loads required to be taken. Speed has involved the introduction of mechanical aids, and the use of cranes; in fact a special 6½ ton bridging crane, on a 10-ton truck chassis, has been introduced into the service, enabling quite large components to be handled, such as HGB panels (1,500 lb), and

cross girders (26 ft long), and the pontoons of the heavy ferry and LAFB.

The weight of these components would appear at first sight to fail in fulfilling the need for lightness. But it is overall economy in weight that is required, rather than the ability to handle by manpower alone; for there is always a need to reduce the tonnages of material in the logistic supply system. Thus it is essential to use high strength light-weight materials.

*Materials.* The weldable qualities of high tensile structural steel were largely developed in the first place to meet the requirements of military bridging, such as the Bailey bridge. The latest steels used in the HGB and the LAFB are low carbon manganese molybdenum and molybdenum boron high tensile structural steels. They are employed particularly for components that have welded members under stress, and enable very high working stresses to be used.

During the war the shortage of aluminium, and the priority given to aircraft precluded the use of light alloys for bridging. Now, however, the production is so much increased that there is no such prohibition. More than ever, therefore, has light alloy been used in some of the bridges already mentioned, particularly for pontoons and decking of roadways. These uses have required considerable development of welding techniques, especially for thick structural sections; and the fullest possible advantage has been taken of the extrusion process, to achieve sections of convenient shape.

One advantage of light alloy for the roadways is its resistance to abrasion; traffic tests have shown that its wearing qualities resist the punishing effect of steel tank tracks. It is comforting to know that Sappers no longer have to put down special wearing surfaces, as had to be done on the timber decking of Bailey bridges, when used for long periods in World War II!

The durability of light alloy has also proved of great value in pontoons. The plywood and timber used in war-time pontoons did not last well, and although the development of plywood with impregnated veneers has greatly improved their resistance to fungus and insect attack, there is no doubt that light alloy needs far less maintenance. Where the pontoons themselves require high strength, such as in the heavy ferry, it has proved necessary to take special measures to reduce the risk of "stress" and "layer" corrosion. These are forms of inter-crystalline corrosion to which heat-treated high strength light alloys are subject; spraying with pure aluminium is the remedy. A strong aluminium alloy that does not suffer from this fault is a long-felt want, which there is some hope of achieving.

Reinforced plastics such as glass fibre laminates appears to have great advantages, in having a high strength to weight ratio, not being subject to corrosion, and needing no maintenance. However it has not so far proved economic for military bridging on any extensive scale, although the US Army have used it successfully for assault boats. One of the difficulties is to build in a strong metal connexion, such as at a heavily loaded joint between pontoons; another is that there is some loss of strength in water. Furthermore it is difficult in manufacture to ensure consistency of the material on a large scale.

*Testing.* In view of the large quantities of military bridging required, and the high stresses are necessarily used, it is worth spending effort and material on full-scale testing, including, if necessary, testing to destruction. Modern developments in strain gauges make possible a fairly accurate assessment of the distribution and magnitude of stresses to confirm the design calculations;

10 TONS MAX. ALLOWABLE  
SIDE LOAD ON BALL JOINT

6 TONS MAX. ALLOWABLE  
LONGITUDINAL LOAD ON  
BALL JOINT

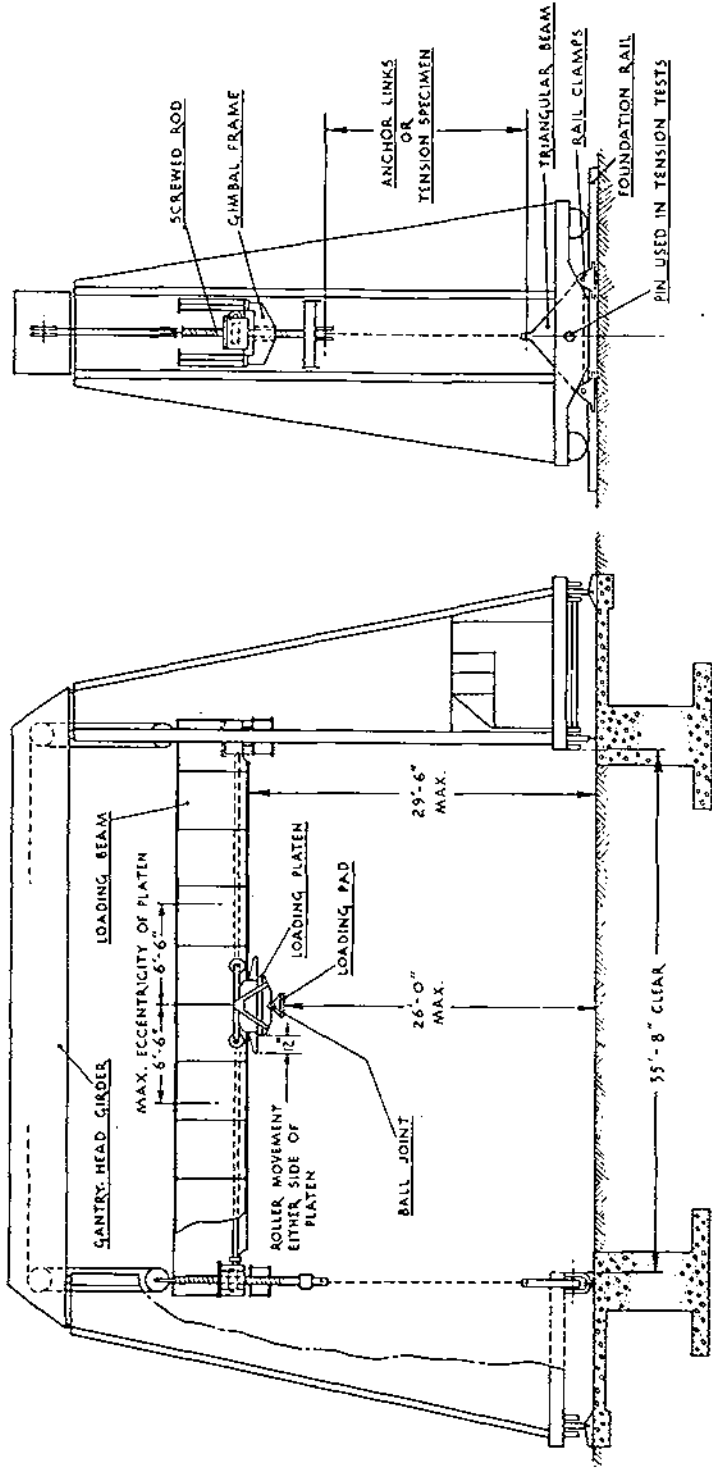

FIG 1 MEXE BRIDGE TESTING RIG

and it is comparatively easy to stop a test before irreparable damage is done. Nevertheless it is desirable to know as much as possible about the design, including sometimes the mode of failure, as when studying the stability of the compression chord of a bridge. Thus overload testing is carried out, with careful measurements of stresses and of deflections, often up to the point where failure is just about to begin. A set of empirical rules for testing military bridges was approved by the Structural Engineering Committee, appointed during World War II by the Scientific Advisory Council. These rules are still applied, and are as follows:—

(a) The bridge under test carries the maximum design dead load.

(b) A load 50 per cent in excess of the design live load, including an allowance for impact, is applied at maximum eccentricity. This is repeated ten times, and if no permanent set takes place at the eleventh application, the bridge is considered satisfactory.

(c) Alternatively (to cover the case of a long and fairly heavy bridge required to carry low load classes) the bridge is tested by applying 1.25 times the maximum dead load plus live load, including impact. There must be no permanent set after the tenth application of this load.

The heavy loads involved are applied by means of the MEXE Bridge Testing Rig, a description of which follows. This rig for 500-ton load was designed and installed at Christchurch to replace a "Heath Robinson" rig, consisting of a long Bailey bridge, one end of which was supported by loading beams resting on the bridge under test; the load being varied by driving tanks to different positions on the rig; jacking this load down a number of times was a laborious and slow task.

*Bridge Testing Rig.* A sketch of the bridge testing rig, and a photograph are at Figs 1 and 2. It consists of two independent rail-mounted gantries, which can be spaced from 19 to 150 ft apart between centres. Each gantry carries a loading beam able to apply a downward load of up to 250 tons through the ball-joint of a loading platen. This load is exerted on any structure under test through a loading pad and spreader beams, which can be suitably arranged to represent an appropriate distribution; for example, to simulate the deck loadings of the wheels of a multi-axle tank transporter. The size of structure or structural element that can be tested under the gantry loading beams is up to 35 ft wide, by 29 ft high, by 600 ft long.

The loading beams can move downwards whilst applying load, and so follow the deflection of the structure; and its rate of descent can be varied during loading to suit the stiffness of the structure. Eccentric loading can be applied by setting the loading platen off-centre; and it is provided with rollers that allow a limited movement to enable it to follow the torsional deflection of the structure.

To measure the load there is a load cell immediately above the ball-joint of the loading platen; this is a circular steel column around the middle of which are mounted electrical resistance strain gauges; compressive strains on the cell change the electrical resistance by amounts proportional to the applied load. The load is shown on a dial of a self-balancing load indicator in the control cabin built into the base of one of the towers of the gantry.

The load is applied to the loading beam by two screwed rods, each rod passing through a motor-driven nut mounted in a gimbal frame at each end of the beam. Cross-heads prevent rotation of the screwed rods, and the nuts are turned by a motor in the loading beam, thus driving the beam up and

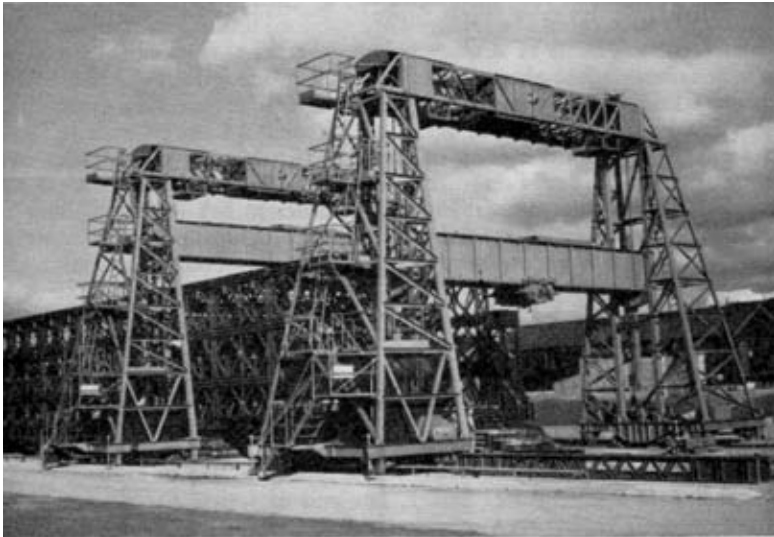

**Fig 2.** MEXE bridge testing rig

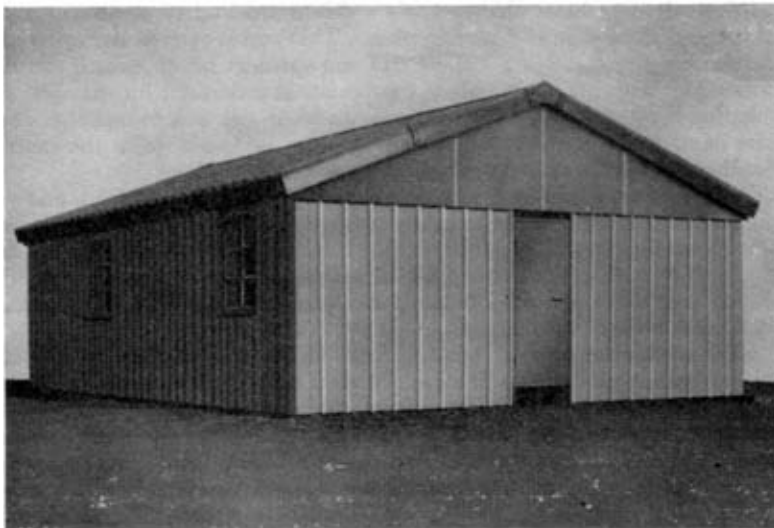

**Fig 3.** Twynham hut

## The Deveopment Of Engineer Equipment For The Army 2,3

down. The lower end of each screwed rod is anchored to the inner foundation rail by means of anchor links and a triangular beam clamped to the rail by two clamps. As the loading beam is driven down it applies a downward vertical load to the test structure, the upward reaction on the beam being resisted by the dead weight of the massive concrete and steel foundations to which the rails are attached.

Alternatively, tensile tests up to 150 tons can be carried out on specimens suspended vertically in the place of anchor links, between the end of a screwed rod and the triangular beam.

The cabin in each gantry has controls for the motors that drive it along the rails to the position required; for the motor in the loading beam; and for the motor in the gantry head girder that drives SWR tackles to lift the loading beam into position before inserting anchor links or tensile specimens. All motors are electrically driven, and numerous limit switches and safety devices prevent overloading or misuse. The cabin can also house recording apparatus for readings of electrical strain gauges on members of a bridge; but a separate mobile cabin may be required.

This testing rig is unique, and has been used for tests on behalf of outside bodies, such as for a structural committee of the British Standards Institute. It is also used for tests on commercial structures, on repayment by industrial concerns.

*Other Tests.* In the development of military bridging a number of tests must be carried out other than purely structural ones. Most of these tests are aimed at proving that the bridge satisfied the military characteristics required by the War Office. For example traffic tests are necessary to establish that the bridge decks will stand up to the wear caused by tank tracks. Other tests are required to establish facts, such as launching and construction characteristics: the amounts of sag in the launching noses, the effectiveness and durability of launching rollers, or the times of construction, to give some examples.

In the case of a pontoon bridge, model tests are carried out in a hydrodynamic test rig, at a fairly early stage of the development. This rig consists of an open flume in which the depth and speed of the water can be varied, the models being suspended against the flow by threads, which can be connected to a balance, to enable a measure of the water resistance to be obtained. Either single pontoons, or a raft, or a complete model pontoon bridge can be tested. Measurements are taken of freeboards, and of the wave formation at different speeds, and this can be done for different shapes, to establish the best bow shape. The results from these model tests have been found to be remarkably accurate, by comparison with full scale tests. Furthermore this rig enables the effect of comparatively shallow rivers to be assessed; whereas the normal ship model tank, in which the model is towed through the water, is not so representative of the true conditions for a pontoon bridge.

#### STRUCTURES

Certain structures are related to bridging, such as bridge piers; they are normally therefore built from components of standard equipment bridges, in the same way as the panel piers of the Bailey bridge, and come in the same category. The only military engineering field equipment that can be described as structures are prefabricated huts, and shelters, both of which illustrate certain facets of development.

*Hutting.* After World War II the need became apparent for a hut to replace the Nissen Hut, to be more suitable for dismantling and re-erection, to be more versatile, and to suit the needs of the three services. By 1951 a Joint Services Committee had worked out and agreed a general specification of the requirement. They concluded that two "light" huts were needed; one of 20-ft span for living accommodation, and offices; the other of 30-ft span for hospitals, small workshops, canteens, and stores. They also specified two "heavy" huts of 48-ft span, one with a gantry crane, and the other without; these were to replace the Romney and Marston sheds. But for reasons of economy this latter development has been suspended. In any case, from the outset, priority was given to the smaller huts.

At the time no effort was available at MEXE, and so two firms of consulting engineers were engaged to make surveys of the commercial field of temporary building structures. As the result of their reports two designs were considered to come nearest to the rather stringent requirements of the specification, and design contracts were placed. Then, when the first hardware from these modified commercial designs appeared, and progress and expenditure were reviewed, it was decided to concentrate on one design. By this time staff were available at MEXE to control the development contract, and to introduce fresh ideas into the selected "Buckwyn" design, to simplify it and make the frame easier to erect. The resulting product is the Twynham hut, named after the original town which is now Christchurch.

*Twynham hut.* A picture of the 20-ft span Twynham hut is given in Fig 3. It is a simple portal framed hut, the frame of which is designed to stand a wind loading of 80 mph and snow load of 20 lb per sq ft, without relying on the cladding for strength; this is to enable any available cladding to be improvised if necessary, such as canvas or corrugated sheeting. Standard cladding is, however, normally provided, either galvanized steel or (particularly for tropical huts) aluminium sheets, to a proprietary design. The standards of accommodation can be varied to suit requirements; for example, the addition of linings and floors are optional, according to whether the hut is needed for an unheated store or for a hospital ward.

Two span sizes are available, 20 ft and 30 ft, with bays 8 ft in length. The galvanized steel stanchions and rafters are bolted together to form the frame, with horizontal wall-rails and purlins bolted to them. The standard cladding sheets, each covering a width of 1 ft, are hooked on to the wall-rails or purlins by special clips, consisting of bent galvanized steel strips rivetted to the sheet along one leg. The sheets overlap each other by one corrugation, and thus hold together. These features achieve the intrinsic characteristics of the design; ease and speed of erection, dismantling and re-erection, with the maximum recoverability of the materials. The hut may be erected either direct on the ground, with a minimum of preparation, or on fully prepared foundations of a permanent nature.

The walls are lined internally with chipboard, and the ceilings with insulation board. Temperate and tropical versions of the hut are available, the latter with extended eaves or verandahs. Thermal insulation is achieved by a combination of internal lining, external cladding, and insulation material in the wall and ceiling cavities; thermal transmittance values obtainable (in BTU per sq ft per hr per deg Fahrenheit) are 0.15 for the temperate, and 0.25 for the tropical versions.

Door and window arrangements are capable of simple variation to suit



requirements. The length of the hut may be varied by the 8-ft module, and huts may be erected side by side, or in "L", "T", or "cross" plan shapes. In addition to the insulation materials, accessories include black-outs, fly screens prefabricated floor panels, flue coamings, and valley gutters. Several special components are of course necessary for the variant shapes of hut. For the 30-foot hut special stanchions and rafters are required, but many of the other components are common. Rolling shutter doors are provided for it.

There is no doubt that the Twynham hut will make a great difference to the comfort of the Army, and will enable huts to be erected and dismantled where formerly tented accommodation was used, such as in the Middle East.

*Shelters.* In the design of underground shelters and protective works in the field there is a clear need to reduce the logistic load of material to be supplied. It follows that it is important to make as much use as possible of the earth cover. Little is known about the effect of this cover, particularly in the distribution of load from the pressure wave of an atomic weapon to the underground structure. Therefore to enable research to be carried out a shelter test rig has been constructed at MEXE in which model tests (for example at one-third scale) can be carried out under a static load. This rig (a section of which is shown at Fig 4) consists of an earth-filled box, 24 ft square in plan; this can contain a test shelter shape, such as a horizontal tube. Above this is an inverted tank, with stiff sides and upper face, and a watertight rubber diaphragm for the lower face. This tank is filled with water under pressure up to 50 lb per sq-in, and is restrained from lifting by stiffening girders across the top, which connect with vertical links embedded in reinforced concrete restraining beams built underneath the rig. The whole structure is thus an enclosed self-restraining unit, which can bring pressure to bear on top of the earth in it, and so on to the model shelter.

The side walls of the rig can be built up in sections so that a variety of depths of cover can be obtained, of up to 4 ft over a 2 ft 6-in diameter model. The walls are also far enough apart to avoid any side effects due to friction on the walls. Holes in the two end walls enable an extension to be placed at either end of a test specimen of the same diameter, through which to inspect results and to take cinematograph films. Filling, compaction, and moisture content of the soil need to be carefully controlled, so as to ensure uniformity. The whole rig is therefore housed in a large weatherproof hangar, with gantry crane for lifting the stiffening girders, and with hoppers to store the soil when not in use.

This work is one of the forms of long-term research that development requires. The result should be that the most efficient shelter can be designed, given a certain depth of cover, a known type of soil, and a selected shape.

#### CONSTRUCTION PLANT

*Historical.* One of the primary reasons for the expansion of MEXE after World War II was the need to develop and test plant for earth-moving, and for the construction of roads and airfields. There had been very little plant of British manufacture available, apart from some items such as crawler excavators of the Ruston Bucyrus type, which were not suited to mobile warfare; there were no bull-dozers, scrapers, or graders, and the Army had to depend almost entirely on plant manufactured in the United States. There was no testing establishment, and such limited trials as were carried out were of a

combined user and technical nature, for which the Headquarters Mechanical Equipment Units were responsible, added to their training tasks.

There was a very limited amount of special earth-moving development carried out, such as "Nellie" (a name derived from the initials of the *pseudonym* Naval Land Equipment). This is referred to by its famous originator, Sir Winston Churchill, in his memoirs. He initiated the project when at the Admiralty at the beginning of the war. It consisted of two enormous and complicated machines, designed to sap towards the Siegfried Line; one to produce a narrow trench for infantry, and the other a wider one for tanks. Development was done under the auspices of a special branch of the Ministry of Supply, and trials were carried out in Norfolk. However by 1942 a more fluid nature of warfare had developed and there was no longer a requirement for these machines, so they were mainly scrapped.

There was also some development in fitting dozer blades to tanks, because armoured columns found themselves held up by rubble from demolished buildings, in the narrow streets of Italian towns and villages. Since then in each family of tanks there has been a tank dozer; development of this is the responsibility of the Fighting Vehicles Research and Development Establishment, at Chobham.

Towards the end of the war, the Experimental Tunnelling Establishment (ETE) at Christchurch, had its effort turned more in the direction of mechanical plant, since there was no further need of tunnels, or of explosive-filled pipes to be driven under roads and airfields for demolition purposes. When the ETE and staff transferred from HQ Mechanical Equipment Units were formed into the Mechanical Equipment Wing of MEXE there was a clear need to expand this to cover the development and testing of plant. In this expansion care was taken to introduce staff with a wide experience of earth-moving tasks during the war, including an Australian, Lieut-Colonel G. L. A. Coates, OBE, whose contribution to the development of construction plant for the British Army has been incalculable.

*Facilities.* The need for rigorous testing has already been mentioned. Methods of achieving this have had to be developed, but when dealing with earth-moving plant the most difficult thing is to ensure consistency; accordingly the testing facilities have had to be developed with this aim in mind. Further, large volumes of soil need to be shifted, in testing the robustness of a large scraper or bulldozer. Consequently there was a clear requirement for an extensive area of ground. MEXE were fortunate in being able to obtain such an area only 7 miles from Christchurch.

In this area have been constructed several permanent facilities, and the remainder is allocated to different tasks, including test roads and trackways. When one area has been thoroughly churned over by plant under test it is levelled, seeded with grass, and allowed to settle, to be re-used in later years, by which time it will have recovered some of its original consistency. There are also some standard digging pits with various grades of imported soil.

The majority of the facilities have been built during the course of the performance and robustness testing of items of plant. For example, tests on tractors hauling scrapers have been used for any levelling necessary, or for preparing the formation for access roads.

*Tracks.* Some of the most important of the test facilities are the test tracks. These include a measured quarter-mile, for speed and braking tests; a lane paved with dense tar surfacing of high adhesion value, for measuring the

SHELTER TEST RIG.

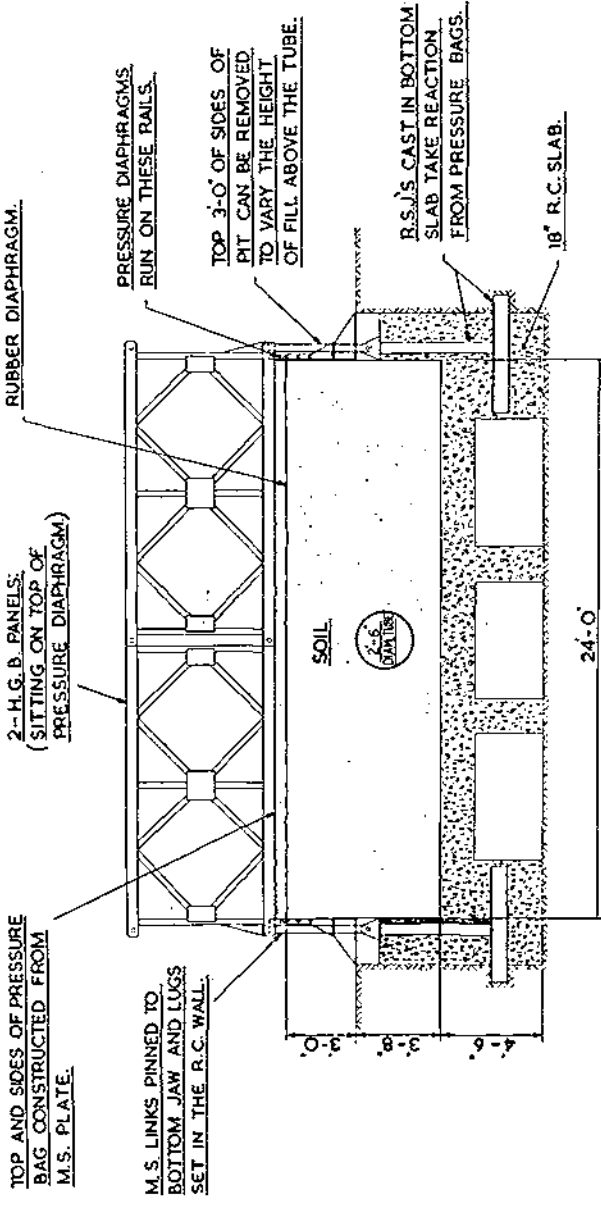

TYPICAL SECTION THROUGH TEST PIT

FIG. 4.

reserve tractive ability of wheeled self-propelled plant, such as wheeled tractors, loading shovels, motor graders, and motor scrapers; a lane for measuring tractive ability of tracked tractors; and a lane for assessing mobility on beaches, half the length being shingle, the other half being sand. The tracked vehicle lane illustrates the means adopted to achieve consistency. It is constructed of 9 per cent rubberized bitumen, 89 per cent stone, clay and sand, and 2 per cent hydrated lime; this resulted from six years of research and development. The track offers constant properties in a wide range of conditions of temperature, humidity and saturation, and enables the maximum draw-bar pull to be developed with the minimum of track slip.

*Dynamometer Vehicles.* Two dynamometer cars have been developed, one tracked (on a Churchill tank chassis) suitable for evaluating tracked vehicle performance, up to 80,000 lb pull; the other being wheeled, able to measure up to 30,000 lb pull. Either car provides controlled drag; when towed by a test vehicle the car's transmission operates a pump capable of consuming the maximum horse-power required, and controlled by a stop valve. The pull is taken through a lever acting on a load cell, which is hydraulically operated, its pressure being indicated on a gauge, which is calibrated in terms of actual pull. The measuring and recording gear enable the following information to be recorded; draw-pull, true progression speed, track (or wheel) slip, engine revolutions, time, true distance covered, and mean draw-bar pull, as indicated by integrators. The tracked dynamometer car has a pair of rollers behind, which can be lowered by hydraulic means, and are used to reinstate the damaged surface of the test track.

*Stability tests.* To ascertain the weight distribution of a machine, and to find the critical angle at which it becomes unstable, it is driven on to a tilting platform. (Fig 5.) This is hinged along one side and operated by hydraulic jacks so that it can be tilted to the point at which the machine would overturn if not restrained. The same platform can be used for static brake tests, by driving the machine on at right angles to the hinge, and then tilting it. This platform can also be used to confirm that the engine can run safely at the specified maximum angle of tilt.

Another rig has been developed for measuring the fore and aft position of the centre of gravity of a machine. This is a simple centrally balanced beam, constructed of heavy girder bridge components; the machine is driven on until the beam is just balanced and the position of the centre of gravity is then found with the aid of a theodolite, and marked on the machine.

There have also been constructed several test slopes, for automotive tests of earth-moving vehicles and cranes on prescribed gradients; a grass-covered slope of one in two for tracked vehicles, and slopes of one in three, one in four, and one in ten, for wheeled vehicles. The surfaces of the latter slopes have been carefully constructed to ensure constant high adhesion in wet or dry conditions.

Stability tests also need to be carried out on cranes. The tilting rig can be used for these; and in addition a level platform is available on which standard weights can be lifted, to measure the stability at varying outreach.

*Earth-moving tests.* Displacement of different soils by earth-moving machines must be measured on a quantity and time basis. Prepared areas of sandy loam, clay, and sandy clay are used, in which reasonable consistency is obtained. When appropriate, different operators work the machines for successive periods, and the results are averaged; but when maximum per-

formance is being assessed, the best operators are employed. Because of the difficulty of ensuring consistent results in different conditions, it is sometimes necessary to have a control machine working at the same task, as a comparator, and then to alternate the drivers between it and the test machine. These are some of the measures taken to eliminate variable factors, and to ensure consistent and reliable results.

*Civil tests.* Commercial firms can pay for the use of these facilities, and for the testing of their plant against recognized test codes. In this way MEXE can keep a very close watch on commercial developments, and obtain a first assessment of the performance of newly marketed machines. This assessment enables selection to be made of machines suitable for military requirements; or of such as need the minimum of development to meet those requirements. Furthermore, this testing increases the knowledge and experience of the project officers, who thus become more useful in the more military development tasks.

*Military plant development.* So wide is the range of plant with which the Royal Engineers are concerned that it could not be covered comprehensively within the limitations of this paper. Apart from tractor-dozers, shovels, and diggers, which are the main tools of field squadrons, there are all the types of plant that need to be available for construction projects—such as scrapers, excavators, rollers, rock crushers, gravel screening plant, bitumen plant, pavers, concrete mixers, and soil stabilization plant. It is necessary therefore to select a few items that illustrate various types of development:—

(a) *Motor grader, 12 ft mouldboard.* This was one of the first items of plant to be developed at MEXE, by means of a development contract with a commercial firm. This was necessary because there was no British built motor grader available. It is a six-wheel machine, the rear four wheels being driven, and it is powered by a Leyland engine. Many machines were manufactured for the Army, and encouraged by this order the firm were able to put the machine into commercial production. The subsequent large export orders fully justified the method of development, which illustrates the encouragement given by MEXE to the British earth-moving plant industry.

(b) *Medium Wheeled Tractor ("Gainsborough").* The Gainsborough tractor was a purely military requirement, based on the need for a tractor-dozer that could travel on the road under its own power, and yet be reasonably efficient in earth-moving tasks. Its development followed a somewhat chequered career. In the first instance it was developed under contract by the Daimler Company, and prototypes were built, with a Daimler engine, and with cable control. But a change of policy by the firm resulted in the need to transfer the development elsewhere. Furthermore, hydraulic operation was preferred, and also the engine had to be changed to one acceptable to the War Office. No firm could be found to undertake the completion of development unless the War Office could guarantee an order for production of at least fifty machines. Eventually, after competitive tenders from those firms that were interested, the contract was awarded to a firm in Gainsborough; hence the name.

The machine can be equipped either as a dozer, or as a loading shovel, and it can pull a 6 cu yd scraper. It carries a 10-ton hydraulically operated winch. With a maximum road speed of 30 mph, its four-wheel drive and four-wheel steering give it an excellent cross country performance. Its earth-moving performance is approximately that of a Size 3 crawler tractor, in all but the most unfavourable conditions.

(c) *Light Wheeler Tractor*. This tractor has been developed to meet the requirement for a universal tool for field troops, to economize in manpower, and to assist in a wide variety of engineer tasks, including lifting and carrying engineer stores in the field, bridge building, loading tippers, digging field defences, and light dozing, such as in preparing bridge approaches. It needs also to have a good road and cross-country performance. Development consisted in taking a commercial wheeled shovel, fitting and proving a "back actor" excavating equipment, and developing a "dual steering" mechanism. The latter is required so that the driver can face either way; for stability in road movement, the steered axle needs to be in front; and for shovelling or dozing it must be at the rear, to avoid undue load on the steering joints.

The first commercial machine to be accepted with these modifications was a British built dual steer wheeled tractor to a proven American design. It has a road speed of 26 mph, and is fitted with a 1 cu yd bucket; a small crane jib can also be fitted, or a fork lift attachment; and a proportion of field unit tractors are fitted with Sherman back actors. It is air-portable in the Argosy transport plane.

The dual steering is an example of the need to incorporate special military requirements in what is basically a commercial machine; it is essential, for military use, whether civilian contractors want it or not.

(d) *High Speed Road Surfacing Unit*. After World War II a requirement was specified by the Engineer-in-Chief for a machine that would tar-spray and blind roads at speeds up to 15 mph, in order to maintain roads with the minimum of interference with traffic. This led to quite a long period of development, because no civil machine could be found that would even approach such speeds. During this development, a new principle was established; that if the grit is dropped on to hot tar or bitumen before a skin has formed, not only can a very high viscosity material be used, but also it holds the grit immediately. In normal commercial practice, gritting follows behind the spray tanker, and the grit has to be rolled into the tar. The MEXE machine illustrated in Fig 6 avoids this, and traffic can follow immediately after it, without picking up the grit.

This machine is designed to sweep, spray with tar, and grit a 6-ft lane at variable speeds, up to 15 mph. It carries 11 tons of gravel, sufficient to cover a length of 2,000 ft at one filling. The tar is kept hot and is sprayed through oil-heated spray bars. Metering devices automatically regulate the flow of tar, and of grit according to the speed of travel. The grit comes off a belt just behind the spray bars at a backward velocity relative to the machine equal and opposite to the actual speed of the machine, so that it is deposited on the hot tar without forward momentum. One driver and one operator alone are required on the machine, and it is therefore economical in manpower. It can return to a refilling point at over 30 mph.

Although with changes in requirement, this machine may never get beyond the present prototype stage, there is no doubt that the principles established during its development will have other applications, even if it is not modified for the less exacting civil needs.

#### ROADS AND AIRFIELDS

The provision of rapidly constructed roads and airfields has always been a major engineer task in war. With the advent of long-range fighters and guided missiles, the emphasis now is more on airfields for transport planes,

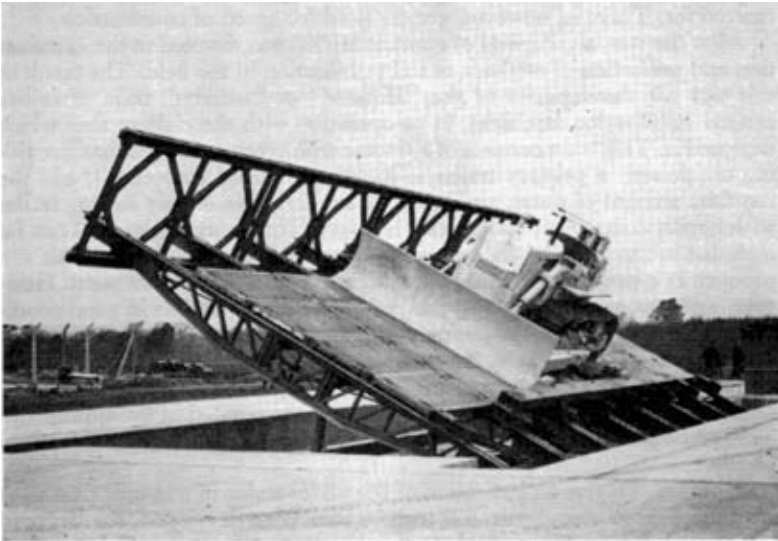

**Fig 5.** Tilting table with crawler tractor on test



**Fig 6.** High speed road surfacing unit

## The Development Of Engineer Equipment For The Army 5 & 6

than for fighter airfields, which simplifies the problem slightly, because the high tyre pressures and landing speeds of fighters no longer have to be catered for. There is, however, greater need for speed of construction.

After the war, a good deal of effort at MEXE was devoted to the examination and perfection of methods of soil stabilization in the field. The result of this was the development of the "Howard" or "Interim" train of *in-situ* cement stabilization machines, in co-operation with the civilian firm which designed it. This train consists of a tractor with creeper-speed gearbox providing the power, a primary trailer to meter and spread the cement, add the requisite amount of water, and break up the soil, a secondary mixing trailer with impact compactor; and a water bowser; a truck carrying cement can be included in the train, or the cement can be put down ahead of it. This can produce in a single pass a lane 6 ft wide, and 8-in depth of pavement. However, even the output of 700 sq yds per hr, which is possible in good conditions, is insufficiently fast to compete with modern needs.

One asset of the research into soil stabilization has been the development of facilities for testing pavements, and for measuring and assessing the strength of soils. The results of the work are incorporated in the appropriate military engineering volumes; but the assets remain, and will be described briefly.

*Facilities.* To give an indication of life under traffic of a sample pavement for an airfield or a road, two test trolleys have been developed, the larger of which is shown in Fig 7. Each trolley has three wheels, one being a load wheel; it has a range of load wheels, and, by the addition of standard weights in conjunction with the appropriate load wheel, the applied load can be varied from 6,250 to 12,500 lb for the lighter trolley, and from 12,500 to 50,000 lb for the heavy trolley; the tyre pressures can be varied from 60 to 300 lb per sq in. The trolleys are operated by diesel engine winches, being towed backwards and forwards over a test area. A dynamometer is fitted at each end, to enable draw-bar pulls to be measured and recorded, and means are provided for measuring pavement deflection under load. These trolleys can be used on test sections, either of chemically stabilized soils, or of mats or membranes laid on the soil, for rapidly constructed temporary surfaces. In each case a series of tests would be made, with different soils, and different conditions of moisture and compaction, in order to assess the limitations of the method.

The basic engineering material in roads and airfields is the soil. Therefore tests of any form of trackway or airfield surfacing must include accurate measurements of soil densities, moisture contents, strengths, and so forth. Accordingly the facilities at MEXE include a well-equipped soils laboratory, and mobile apparatus for soil survey and sampling, and for identification and classification. Needless to say, the fullest value is obtained from the facilities and experience of the Road Research Laboratory, in the Department of Scientific and Industrial Research, with whom MEXE works in close collaboration. But their research is largely in aid of permanent roads, rather than the very temporary ones that form the modern military requirement; consequently some parallel research is necessary at MEXE.

*Current developments.* Speed of construction, and lightening of the logistic load are the primary requirements of approach trackways for bridges, and of short term airfields for transport support. Therefore the use of light alloy planks, of constructions that can be rolled out quickly, and of flexible



plastic membranes must be examined, together with any other methods that may ease the problems, such as the admixture of lime to dry the soil. For none of these developments is it foreseen that there would be any civil use. Nevertheless, the assistance of industry is being exploited as fully as possible, such as in adapting modern techniques of cellular construction for thin planks of light alloy.

#### ELECTRICAL AND MECHANICAL EQUIPMENT

There is a large range of electrical and mechanical equipment used by the Royal Engineers; generators, compressors, pumps, water purification and filtration plant, earth augers, power tools and welding plant are some examples. The majority of these requirements are satisfied by commercial equipment, with the minimum of military modification, such as mounting on standard Army trailers, and painting with the usual green colour! However they must be robust, require the minimum of maintenance with long running time (1,000 hrs is a normal stipulation), and they must withstand the fairly rigorous climatic conditions laid down, such as operation at up to 5,000 ft height above sea level, and in temperatures from zero to 120°F. Furthermore the need for light weight, as already described, sometimes requires special military development. Therefore a large amount of testing, and a certain amount of design work are necessary. For this purpose some excellent facilities have been built, and effort has been increased. Consequently great improvements can be expected in this field during the next few years.

One aspect of electrical and mechanical equipment is worth particular emphasis, namely the increased use of electricity in the Army. The requirements of guided missiles and radar have grown not only in quantity but also in quality. They need more sources of what has come to be known as "precise" power; that is, electrical power with accurate voltage regulation, and with close frequency control, so as to be virtually unaffected by transient changes in demand. Improvements in engine governors and in electronic "black box" control units for regulation make this precise power possible without undue expense. Although other general purpose uses of electric power in the field do not require such accuracy, it is clearly in the interests of standardization for all generators in the Army to be able to meet the majority of needs of the specialist electronic equipment and weapons. Thus the simpler requirements of engineers for lighting, heating, and driving workshop tools are tied to the more exacting demands of the newer weapons. This can have a further all-round benefit, because lighter weight can be achieved by adopting the higher frequencies that are normal to electronic equipment, and the higher engine speeds that can thus be used.

Another interesting development that is likely to come to fruition during the next few years is the introduction of high frequency electric power tools, to replace compressor tools in engineer field units, for all but the major tasks in demolition and construction. Substantial savings in weight and space are to be expected, and the importance of this aim has already been emphasized.

*Electrical and Mechanical Equipment Test House.* The most important facility at MEXE for the testing of electrical and mechanical equipment is the E and M Equipment Test House. It has been designed to provide sound-proofed well-ventilated test beds for round the clock endurance testing of engine-driven equipment, or any rotative electrical or mechanical machinery. It has three cells, one of which is shown in Fig 8, and they are served by one

sound-insulated control room (the window can be seen in the back wall in the photograph), with visual observation of each cell floor. Permanent wiring with terminals are installed between each cell and the control room, for instrumentation; these include thermo-couple extension leads, for recording of temperatures, co-axial cables, multi-core screened cables, and pneumatic lines, for various control tasks. The sound-insulated ventilation in each cell allows diesel engines up to 350 bhp to be run continuously, with the temperature rise in the cell limited to 20°F above the ambient temperature.

The following types of test can be carried out in each cell:—

(a) *Pumps.* A water circuit with header tank, sump, pipes, and manifolds allows continuous pumping at flow rates up to 1,500 gal per min. The circuit can be operated with the pump suction pressurized to 40 lb per sq-in, to represent a pump in series in a pipeline system.

(b) *Electrical generators.* Electrical outputs of up to 250 KVA per cell can be absorbed from generators under test, the energy being dissipated as heat in a ventilated load room, at roof level. A cycle of varying load can be pre-set, to represent realistic performance requirements.

(c) *Engines.* Engines can be "type tested" to an agreed load schedule, by coupling them to hydraulic absorbing dynamometers. These are cooled by a supply line with a thermostatically controlled engine cooling manifold, which allows the installation of an engine and absorbing brake on any test bed in the cell. Heat absorbed in cooling water from the brakes, from engine heat exchangers, or from hydraulic pump tests, is dissipated through Marley coolers. Separate fuels can be supplied through meters to each engine in a cell, so that diesel, petrol, or industrial gas turbine engines can be tested simultaneously.

(d) *Power measurement.* Electrical dynamometers are permanently installed, which are capable of motoring equipment up to 250 bhp continuously, at speeds up to 4,500 rev per min; the power is measured to an accuracy of 1 per cent. Automatic control can be provided for any pre-set programmed cycle of speeds or torques to be imposed on the equipment under test. For example, a programme can simulate the loads imposed by prime-movers on transmission systems in vehicles and plant, or the loads imposed by a compressor.

*Outboard motors.* The endurance testing of outboard motors has required the construction of a test tank, in which a test motor can be mounted. The tank is in effect a water channel in the shape of an elongated ring, with rectangular cross-section. The test motor is mounted on a dummy transom across the channel, and drives the water round it continuously. Vanes at the semi-circular ends guide the water into the straight sections, and the turbulence is reduced by honeycomb straighteners. Electro-pneumatic apparatus can be used to control the motors according to pre-determined cycle; the throttle and gear-lever are operated automatically, and so is a set of sluice-gates to arrest the water when forward to reverse cycling tests are made. Performance tests, and the assessment of generally handling and suitability are, of course, made with the motor mounted on the appropriate craft.

*Other tests.* It is not practicable in this paper to describe all the tests that need to be carried out on engine-driven equipments. For example, cold starting and high altitude tests require special chambers; suppression screening requires electronic equipment; alternating temperature and humidity climatic tests require special ovens; and vibration tests need vibrating tables.



**Fig 7.** Airfield pavement test trolley

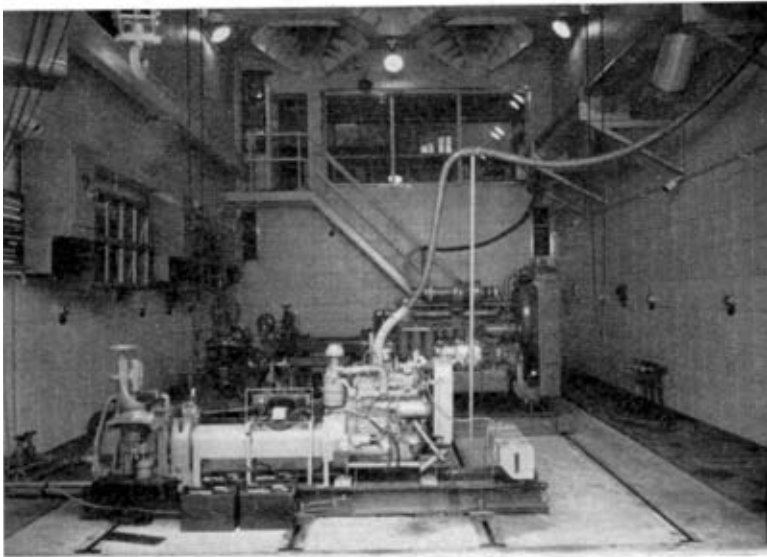

**Fig 8.** Electrical and mechanical equipment test house. One of the test cells

## The Development Of Engineer Equipment For The Army 7 & 8

Many of these tests have to be carried out at other research and development establishments that are equipped for them. Sometimes such tests have to await their turn with other equipment more urgently needed. This is a contributory factor in the time taken in development.

#### PETROLUEM, OIL, AND LUBRICANTS

The need for very rapid construction of pipe-lines and storage installations for POL has led to the development of flexible lines, and collapsible fabric tanks. The flexible pipe-lines can be laid rapidly from a vehicle in continuous lengths; but the pressures possible only allow short distances between pumping stations, compared with those possible in rigid pipe-lines. Therefore aluminium pipes are required for the longer pipe-line systems.

The problems involved in the pumping of fuel through rubber-lined hose, and in storing it in rubberized fabric tanks, are two-fold. Firstly, the plasticizer used in the synthetic rubber lining of the hose is leached out into the fuel being pumped through, and contaminates it to a degree unacceptable for aircraft engines, for example. In the second place, the seams of the collapsible fabric tanks are attacked by the more highly aromatic fuels. The former problem will no doubt be solved by development in industry of suitable means of lining the hose with a material such as nylon. The problem of leaking seams has, however, required special testing apparatus to be developed.

The 40 ft long, 14 ft wide collapsible 10,000 gal storage tanks concerned are made from panels of rubberized nylon fabric, joined at the longitudinal edges by bonding agents. When these tanks were first tested with gasoline fuel in tropical conditions it was found that the seams did not last. The seam testing rig was developed to investigate the cause of failure, and to establish the expected life of any stronger seams that might be developed. A seam of the type to be tested is made in a test specimen in the form of a small open ended cylinder. The ends of the cylinder are closed by means of steel bungs, and rendered fuel-tight by steel clamps. The cylinder is then laid in a cradle in a thermostatically controlled hot water tank, the seam being uppermost. The system is then pressurized with test fuel and bled through to ascertain that no air is present. The specimen is maintained at constant pressure and temperature until it fails; a record is made of the time taken to fail. By altering the pressure in the system and the type of test fuel used a "life expectancy" curve can be plotted for any given type of seam in the test conditions.

Seams of the same type as tested in this rig have been included in tanks exposed to tropical conditions, in order to correlate their life in service with the life expectancy curves obtained from the rig. The results of the series of tests carried out have been to ensure a satisfactory seam design, and to establish a standard test, against which to prove other designs offered by fabric manufacturers.

#### RESEARCH

Mention has already been made of some of the research that is carried out on materials, particularly for bridging and structures. For this purpose MEXE is equipped with a number of research laboratories, including in their scope: strength of materials, strain gauge and stress analysis, fatigue, corrosion, protective finishes, metallurgy, and plastics techniques. Much of this work is applied research in aid of particular projects, but development would

have no firm foundation without a certain amount of basic research. Some of this basic research is done at MEXE, such as the study of the cumulative damage problem ("fatigue") in welded high tensile steel structures. Other work is carried out under extra-mural contracts at universities and industrial research laboratories, or at other War Department and Ministry of Aviation research establishments.

The value of this research is most apparent when it stems from specific problems arising during development, or from an evident need to extend the boundaries of knowledge in a particular direction; that is, when it has a clear objective, rather than an unknown end such as pure research often has. Consequently the basic research considered here must go hand-in-hand with development, and will frequently follow some specific line which a project officer may suggest as worth investigation. For example, if the use of a cold-setting foamed plastic is suggested as a means of providing a temporary approach road across bad ground, research is required into the limitations of the material, before any serious development can start. This applied research may reveal other possible applications; or it may uncover some lack of knowledge that can only be filled by more fundamental research.

The following up of novel ideas, and the research that results, can be stimulated usefully from any direction. Royal Engineer officers, and other members of the Institution of Royal Engineers have a valuable part to play here, since in the course of their varied work they may stumble on new ideas and inventions that prove worth pursuing. Therefore liaison between RE officers and the staff at MEXE is to be welcomed as a means of cross-fertilization of thought.

#### CONCLUSION

The limitations of time and space have prevented a full description in this paper of all the different types of engineer equipment required to be developed for the Army. For example, no mention has been made of bomb disposal equipment, mechanical handling plant such as fork-lift trucks, transportation equipment such as beach causeways, quarrying equipment, marine craft such as bridging tugs, and many other of the stores that need to be developed or tested. However, a representative selection of the major items has been made to illustrate some of the problems in development, and the ways in which they are solved.

Another deliberate omission from the paper is an account of many of the humdrum tasks, such as the writing of user handbooks, the design of adequate packaging, the preparation and checking of drawings and specifications, and the cataloguing and scaling of spares for equipment and plant. These tasks are all important and necessary for the satisfactory introduction of stores into the service, and handling them thereafter; and they involve a lot of time and effort on the part of the design staff.

Mention of these omissions, however, serves to underline some of the conclusions of this paper. Firstly, the range of engineer equipment and plant is so wide, and the factors affecting their requirements are so diverse, that they cannot be satisfied entirely by commercial equipment. Nevertheless, the greatest possible use is made of commercial equipment and components, after thorough and rigorous testing to ensure robust and acceptable articles. Secondly, there is a great need to encourage unfettered forward thinking and

research, so as to stimulate new ideas and novel approaches, without necessarily any clearly stated military requirement. This must of course be set against a general background of knowledge or experience of military problems; this knowledge is inherent in the RE officers and the majority of the civilian staff at MEXE. Thirdly, the development process in peace-time is necessarily laborious, and consequently a lengthy one, if risks are to be avoided. This time scale can be reduced by careful assessments and feasibility studies to eliminate abortive work, and by other means; but some delays are inevitable if adequate trials are to be carried out, and satisfactory stores are to be introduced into the service.

The descriptions of facilities and of development work given in the paper, although far from comprehensive, do illustrate some of these conclusions, and reveal some of the particular problems that arise during development. Difficult though these problems sometimes are, in the widely varied types of equipment developed for the Royal Engineers, the staff at MEXE are dedicated to their solution, and no tribute could do justice to the keenness and ingenuity of this fine body of scientists and engineers. They follow the path set first by Martel, continued by several RE officers since his time, such as Galpin, Stewart, McMeekan, Jefferis and Fayle, and brought to a plateau of efficiency by Sir Donald Bailey.

# Coopers Hill War Memorial 1959 Prize Essay

THE following subject was set for the 1959 Prize Essay:

*“As a supposition, the Regular Army of the future may well be involved, in an overseas theatre, in operations consisting of:—*

*A build-up of forces to prevent war breaking out;*

*a war itself with a possible nuclear threat;*

*and finally, the occupation of the country which may well be undeveloped.*

*You should assume for the purposes of this paper that the force will consist of not more than two brigade groups. Speed of development in the initial phase will be essential.*

*You should also assume that it is unlikely that nuclear weapons will be used other than tactically, nor active operations last for more than a very few months.*

*Subsequently the country may be occupied for a period of months and engineer assistance may have to be used for civil affairs purposes.*

*Discuss the problems which the military engineer will face in such operations and consider whether the current organization and trend of the Royal Engineers is fitted to meet them.”*

The Council of the Institution selected the following essay, by Major I. T. C. Wilson, MBE, MC, RE, as the prize-winning essay from six essays submitted.

## INTRODUCTION

The problem is for the Royal Engineers to meet the conditions and tasks set them by the transport and build up of a force overseas to a territory which is being threatened by an aggressor, then to support those forces in a small war in which it is assumed, tactical atomic weapons are used, and subsequently to face the problems of occupying the disputed territory, running down the forces and restoring the country to independence. Consideration of the problem stems from the needs of the force. In the first phase the task is to move, establish the force on a foreign territory and by its presence and actions, to deter the aggressor from moving. The second phase is simply a war, in which the enemy must be met, held and defeated. The third phase, the occupation, is the most complex and the tasks are difficult to define. It will be largely a matter of supporting the recognized government of the country in question until it is strong enough to support itself. In each phase the needs of the expeditionary force for engineer support will be, to some extent, different and will require sappers trained to do different tasks. Yet, despite all their versatility, sappers cannot be trained to a new task overnight. The establishment of a reserve of sappers trained and ready for the next task presents a problem of its own which threads through the whole discussion.

## PHASE 1. THE BUILD UP OF A FORCE IN AN OVERSEAS TERRITORY

The mobility given to the Army today by transport aircraft can produce a rapid concentration of troops in an overseas territory provided that airfields are available. However, although there are few countries in the world

where there are no airfields, in a poorly developed country they are not numerous. They are used principally and probably to near capacity by civil airlines who will object strongly and increasingly to disruption of their services. From the country's point of view too, major disruption of air schedules cannot be tolerated for long. Furthermore, if the airfields are few in number, the dispersion of men and supplies from the airheads may cause trouble and they become obvious preselected enemy targets. More new airfields, even if suitable only for the tactical air freighter, are likely to be required.

Movement of materials by air has its limitations. The size and weight of air transported loads is carefully regulated. An expeditionary force can be moved swiftly with light scales of transport and equipment but may be hampered in its operations for lack of heavier equipment. Much will depend on its training. The heavier materials can only be brought in by sea. This implies the running of a port, possibly opening a new port or extending the facilities of an existing one. Until a port is working and the ships are discharging their cargoes, in particular the heavy plant, it is unlikely that any real progress can be made towards the build up of the territory as a base for operations.

From both the airfields and the ports communications will be required to carry the material to the camps and depots from which the force will operate. Railways at this stage present little problem. If they exist, it may be assumed that they will continue to run and can be made to cope with the extra traffic required, although some adaptation to rolling stock may be necessary. Similarly, the main roads are unlikely to compel development, nor would there be time to do so except for the simplest tasks to clear bottlenecks. The major effort on land communications is likely to be on the routes required in the depots and the linking of the existing routes for deployment.

The deployment of the force to battle stations will involve reconnaissances of the defence zone by all arms, and possibly some preliminary work. Here, previously collected information about the country would be invaluable, but it is too late at this stage to bemoan the lack of information. In addition the force will need acclimatization and training to fit themselves for action ahead.

The engineer work to support the move, establishment and deployment of the force will be extensive and various. Much will depend on the scales on which the force is to operate. The initial light air transported scales for two brigade groups will require little except for the troop camps, which can be rudimentary. This force should be able to deploy quickly and to establish themselves. However, it would be wrong to use the engineer squadrons integral to the brigade groups on the basic construction tasks. The officers of the squadrons will be required for the brigade reconnaissances and should not be diverted. The squadrons themselves should be free to train with the brigades so that their sapper support achieves at least an equal standard of field training. As time passes after the initial deployment, there will be an increased demand for a rising standard of accommodation. There will also be a requirement for the storage of equipment to keep the force supplied. Much can be stored in the open, but certain items, such as bulk fuel, will need installations which must be built. As more material is landed additional depots must be built and concealed.



### PHASE 2. THE WAR

The war, in which there is the threat of the use of nuclear weapons, and the actual use of some tactical nuclear explosions, will probably take the pattern of a defence wearing down the enemy spearhead followed by his destruction in battle, and then an advance to drive the enemy from the disputed territory. Without discussing tactics, the engineer effort in the combat zone is almost certain to be beyond the capacity of the brigade field squadrons because of the tremendous destructive power of a nuclear explosion. However, any clash of arms of this nature is certain to bring increased world tension, making it difficult to withdraw field forces from other overseas garrisons. The primary engineer task resolves itself into opening and maintaining the tactical routes for the field force, and their supplies. Additional tasks will be the building of obstacles, tactical demolitions in withdrawal, denial of material to the enemy, and probably water supply. The Royal Air Force tactical air force may also make demands on the available engineers. Finally ports, road, rail and air heads must be kept open even though the local civilian labour may have joined refugee columns heading to safety.

### PHASE 3. THE OCCUPATION

The role of the Army changes in occupation from active soldiering to duties in aid of the civil power. Many situations of the type under discussion are accompanied by an internal bid to overthrow the existing order. This introduces an internal security problem which, after the end of hostilities becomes action against terrorists. In any case, it may be assumed that the war will have disrupted the country to the state where the effectiveness of the government is greatly reduced and the public forces have been dispersed or disorganized. The role of the occupation force, therefore, is likely to run the full range from active operations to action helping to restore the prosperity of the country. Furthermore, in a period of occupation, there is almost certain to be at least one national disaster in the form of flood, fire, tempest or earthquake. At the same time the occupation troops themselves will expect, or the British National Press will demand, a reasonable standard of living accommodation. As peace is established and the government grows stronger, they may be expected to take over more and more of the occupation duties and the role of the occupation forces will change to one of cementing friendly relations, training schemes for the services of the occupied country, goodwill attachments and perhaps tattoos and displays. Finally will come the eventual slow withdrawal of the occupation troops, backloading the stores, dismantling the installations and handing back the land used.

There is no diminishing of engineer effort in this phase. The field force will still need their full sapper support. Internal security operations present a series of tasks in which sappers are best suited to take part. Similarly, with other duties in aid of the civil authorities the trade structure of the Royal Engineers produces men with the right qualifications to give assistance. The other engineer tasks will depend to some extent on the ability of the Civilian Works Organization being able to find men to travel at short notice to live in indifferent accommodation and meet their responsibilities. But, there will always be a requirement for a number of semi-official jobs which, because of cost, time or security reasons, cannot be done by civilian labour. It is right that sappers should be able to help the Army to live more com-

fortably, and it will reflect to their credit if these jobs can be done. A final task in this phase will be the clearance from the battlefield of the unexploded bombs.

#### ENGINEER SUPPORT REQUIRED

Engineer intelligence is most important. It is perhaps rather longer term than the period of operations under discussion, but the supply of really comprehensive intelligence about matters connected with the engineer problems in the country concerned will assist greatly the planning of any task. In particular a knowledge of the country in general, possible obstacle lines, roads, railways, ports, suitable sites for airfields and up-to-date information on available resources would be most useful and would save much effort.

An Engineer Staff is required at the Force Headquarters from the very beginning of the planning for the first phase. This staff will have to ensure that they are not excluded from any of the detailed planning and they should be able to represent all forms of engineer support including the Works Organization. The Engineer Commander may find it necessary to acquire specialist staff officers from each of the branches of the Corps who are likely to become involved.

The field force engineers initially will consist probably only of the brigade field squadrons. They must be prepared to operate on light air transported scales only and should be thoroughly trained to do this. The most effective way of ensuring that they are so trained would be for their basic equipment to be light scales. There is a strong requirement for manpower to be supplemented by mechanical plant which ideally would be a section tool. What is needed is a small mobile machine, the size of a land-rover, with a bucket which can dig and load. As an alternative to the bucket, fork lift prongs could be attached, and sappers should be trained to use it for bridging rather than the more cumbersome cranes. The larger plant equipments, although they have a greater work capacity and are perhaps more effective when they get on the job, may never get there because of their bulk and lack of mobility. The infantry brigade field squadron could be a smaller unit than the present establishment, working on a basis of very few vehicles and most of those quarter-ton trucks. It is a luxury to mount the whole establishment in vehicles; like the infantry they support, the sappers should be prepared to march. In the Boer War a field company was expected to march twelve miles and then do a day's work as routine; modern sappers should be no less tough. However, time is often too precious to spend in marching, and sappers must be prepared to travel on to a task clinging to the vehicles which carry the stores. A section vehicle which is usually used as a section home on wheels is too lavish a scale for this type of operation. The section should be prepared to move, live, work, and fight with what they carry, as do airborne forces. This means that new and lighter equipment must constantly be sought as it is developed on the civilian market. An efficient, lightweight sleeping bag is long overdue, long wearing tungsten bits for compressor tools would save weight compared with the greater quantity of mild steel bits which are now carried, and there are many other examples. Every ounce of weight becomes important. Finally the field squadron must never overlook the opportunity to make use of local resources of material, plant and vehicles.

If armoured forces are to be used in any quantity they should expect some measure of armoured engineer support, particularly in the final advance against the enemy at the close of the war. This support could perhaps best be given by an armoured engineer squadron integral to each armoured brigade group. Such a squadron would not need to be the size of the present Corps Armoured Engineer Squadron, and should contain a dismounted troop for certain engineer tasks, such as rafting. The difficulties of training a mixed force of armoured and dismounted troops has been met before and overcome in units such as the armoured car regiment. The armoured brigade engineer squadron would need AVREs and bridgelayers, but would need no plant.

The basic construction tasks required to establish the expeditionary force on the overseas territory and to build up the base for operations, need engineer work in the form of plant and tradesmen. There is, however, scope for the employment of local civilian labour and plant, which now exists even in undeveloped countries, and for contract work. A possible requirement here is for a type of sapper unit experienced in employing civilian labour and letting contracts. The nucleus would be a military headquarters with a certain amount of skilled supervisors and a few sapper tradesmen. In peace and normal conditions, such units could be stationed in the various overseas bases, where there is always a requirement, as in Phase three of this operation, for minor engineer works. The units would thus gain their experience. In an emergency the unit of this type in the theatre of operations could move quickly to the trouble spot, hire labour, buy materials and start work. Their knowledge of local conditions and their experience in the type of work would be invaluable. The problem of finding the necessary manpower for such units might be solved by the decrease in the strength of the brigade squadrons. In the event of a small operation, or during the first few days of the operation under discussion the brigade engineers could be reinforced with a park troop formed from this works unit. It might be appropriate to give this unit the time-honoured name of Fortress Squadron. Some units of this type might also produce an incentive to recruiting, in that they would be employing men primarily as tradesmen.

Civilian labour cannot be employed in the battle zone except in large parties, such as porters and labour gangs, where they can be worked under strict supervision and guarded. The second phase, therefore, introduces a need for more military field engineers. Assuming that the garrisons in Germany cannot be made available, the Corps Engineer Regiments of the Strategic Reserve will have to be used. The workload is likely to be so heavy that no less than three field squadrons and a field park squadron will be required in the combat zone. However, there will be many other probable tasks for these formations outside the combat zone. At the time of the Suez operation, a Corps Engineer Regiment was used together with an Army Emergency Reserve transportation unit, as dockers at Famagusta in Cyprus. Similar needs are certain to arise in this operation despite the increase in size of Transport Command of the Royal Air Force. There is no doubt scope for the reduction of Ordnance holdings and the consequent reduction in the size of depots by more efficient use of air freight, but the demand and variety of tasks for military engineers will almost certainly exceed the supply. The Corps Field Squadrons must be extremely versatile to tackle the variety of tasks, but base units must learn to fend for themselves.

The overseas territory in which the action is taking place is assumed to

be undeveloped. Therefore, the port or ports are assumed to be elementary. The requirement for transportation engineers will be great, and some call-up of the Army Emergency Reserve will probably be necessary. Even this will probably be insufficient to meet the demand. The maximum use of local civilian labour and calls on the corps engineers will have to be made. The nuclear threat will aggravate the problem. Development of speedier methods of handling cargoes by means such as ship to shore helicopter offers the best chance of meeting the requirement.

#### SUITABILITY OF THE CURRENT ORGANIZATION AND TREND OF THE ROYAL ENGINEERS

Much research is being devoted to new and better engineer equipments and techniques. Wheeled tractors increase greatly mobility, new bridging equipment saves much time, use of aircraft simplifies the supply of engineer stores. The process of development is, however, often slow. It is the old problem of the best being the enemy of the good, and by the time a new equipment has been thoroughly tested something better has been thought of and supply is held up. In the interests of standardization and supply it is obviously preferable to find the best, but use of air freight and makers hand-books would enable spares to be supplied direct from any factory, and units would prefer second best to nothing.

At the same time as plant is growing lighter, field squadrons seem to be growing "heavier". If the present trend is followed, a field squadron will be in the situation of having wheeled plant and tracked vehicles. Tracked vehicles, despite their many advantages are invariably heavier and require more maintenance than their wheeled counterparts, and this brings problems of air transport, supply of fuel and spares, the proportion of "tail" to "teeth" and weight of bridging equipment. Furthermore it is not easy in peace to train thoroughly with tracks. The heavier bridging equipments have already brought in their train the bridging crane which is comparatively immobile. The park troop of an independent field squadron increases its scope but also increases its "weight". It might be more profitable to give it the necessary support from an outside unit where the heavier plant can be employed more effectively in bulk rather than split up. The existence of fortress squadrons to carry out works would free the field squadron to concentrate on its primary task of supporting other arms in the field.

Much development and new techniques have in the past been based on the concept of global war starting in Germany. This is not necessarily the right basis on which to produce a force for a campaign in an undeveloped overseas territory. Much emphasis has been placed on the value of carrying out work under the cover of darkness. It is for consideration whether the night is the best time to act when under the threat of nuclear weapons, because it is at night that the flash is most effective. A series of nuclear explosions at night would blind men out in the open at a great range; the effect of this on supply columns, engineer operations, or an attack would be devastating. It is the men who are in defence in slit trenches who are most favoured. The predominant need in Germany is for field engineers working in close support of the other arms. This may have left the rear areas rather short of engineer units geared to trade tasks, but if the rear areas were overrun quickly, because there were insufficient engineers forward to create obstacles on which to stop the enemy, there would be no work to be done.

As a result the Corps Regiments are not geared to tradesmen's work and this process always takes time yet the works requirement exists for the expeditionary force. The strategic reserve engineer regiments based in England can, however, meet the demand.

Field squadrons under command of brigade groups are required when brigades are operating independently. When two or more brigades are operating together a higher control of engineer work is required to plan, co-ordinate and make the most efficient use of the available labour. These tasks would be undertaken by the Engineer Commander at the Force Headquarters, but he might be overburdened in dealing with all the various engineer units in the country, and a need might arise for other engineer headquarters in the chain of command. Assuming that the Force Headquarters will be the strategic reserve divisional headquarters, and the engineer commander the CRE of that division, there may be a lack of a constituted and trained headquarters ready to assume command of the lines of communications engineer units.

### CONCLUSION

There is always a greater demand for engineer work than can be met by the available sappers, in any phase of this operation. The move by aircraft with only light scales of vehicles simplifies to some extent the sapper tasks, but increases the difficulties of carrying out those tasks. It also allows less time for preparation and planning, which is the keystone to a well executed task. The speed of move and the operational requirement will cause difficulties in producing engineer units in the right sequence for the work required. The need to free the field sappers to prepare for battle further complicates the plan. The over-all shortage of military engineers will demand great versatility from those available, and every method of reducing their tasks will have to be investigated. Even in undeveloped countries there are in these days local resources of construction labour and equipment which must be exploited to free the military engineers. Despite recent reorganizations there is still scope for pruning establishments and introducing new equipment, particularly in view of the light scales on which the sappers must be trained to operate. Anything that is not essential must be regarded as a luxury and the current trend towards heavier vehicles in the field squadrons is contrary to this requirement. The needs of the force will dictate the tasks of the sappers, but engineer advice may well alter the operational plan.

# Hovercraft as Tank Carriers

By MAJOR A. J. D. HUGHES, RE

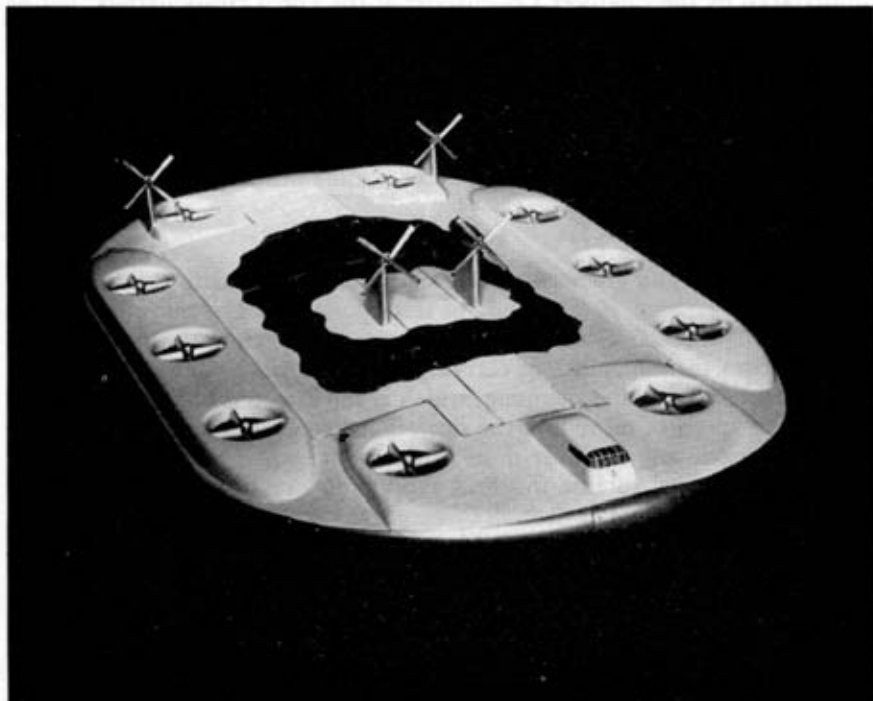

## FOREWORD

THIS subject was selected as the design exercise set to a small group of officers of the Fighting Vehicles Group of the 13th Technical Staff Course during the final part of their two-year course at the Royal Military College of Science. The author was appointed leader of the team and would like to emphasise that this article represents only a résumé of the exercise and that each part of it was largely the work of different team members. The other members of the team were:—

Major E. A. McCloskey, RAE, Major C. Hartington, RE, Major J. B. Willis, 10 H, Major B. J. Falvey, RA Inf, Captain J. C. M. Staddon, RASC, Captain E. T. Luscombe, RE.

The Directing Staff was represented by Lieut-Colonel K. L. Taggart, RE.

## PART I—THE NEED

### BACKGROUND

There are many areas throughout the world where British Troops may be called upon rapidly to carry out operations of a limited nature requiring a properly balanced force including armour.

Up to now the transport of tanks to distant places has often involved movement by sea, either preceded or followed by movement by rail or transporter with the corresponding inevitable delays in the execution of a plan where speed of deployment of the force was highly desirable.

So far as can be foreseen there will not in the foreseeable future be an aircraft capable of carrying such a concentrated load as a 50-ton tank and, even if this were possible, such an aircraft would require a long and strongly built runway on which to land and such a runway may not be available near the area of operations. Helicopters could provide a form of aerial crane which could possibly lift a tank, but the extra fuel load required to achieve a significant range would prohibit their use in the required role.

### AIM

The aim of the design exercise was, therefore, to consider the feasibility of using a Ground Effect Machine (GEM) as a tank carrier.

### MILITARY CONSIDERATIONS

A British Force sent to a trouble spot in order to prevent an "incident" developing into limited war might vary in size from a Battalion to a Brigade Group in strength. It is logical, therefore, to consider a Squadron of tanks as being the smallest self-contained armoured unit likely to be needed.

For the purpose of the exercise it was assumed that the distance between the mounting area and the destination of the force might be in the order of a thousand miles or more, and that all elements of the force would be air transportable, except for the tanks which would be carried in GEMs.

From the military point of view of ease of command and control it was considered that the ideal lift for one GEM would be one troop of tanks, that is to say three or four tanks. This would have the further advantage of delivering in one craft a tactically effective sub-unit to its destination.

### VULNERABILITY

A GEM would be subject to normal enemy attack but a new consideration is its speed of movement as a land and sea vehicle. As a sea vessel, it would not be subject to torpedo attack, nor vulnerable to mines or underwater obstacles. As a land vehicle it would not be hampered by minefields. Owing, however, to its size and comparatively slow air speed, it would be most vulnerable to air attack and normal land-based gunfire. As the machine would be used as a long distance transporter, travelling mostly over sea routes and land in friendly hands, it would not be generally used in forward areas and it would not, therefore, require armoured protection. In any case weight and size limitations would make this impossible. Militarily, therefore, if a GEM can offer rapid movement of tanks direct from a base to the area of operations it will not only save time but obviate the necessity for providing beach or port facilities followed by rail or road communications and bridges up to tank classification standards.

### THE DOMINANT TECHNICAL CONSIDERATIONS

The technical details of the craft will be discussed later, but the following basic facts which determine the size of a GEM or hovercraft are outlined below:—

(a) *Load to be carried.* Due to power economics, as the craft increases in size the power per ton of payload decreases. This is common for many vehicles. Also all vehicles increase their range with size. This is because the spare carrying capacity available for fuel increases more rapidly than the rate of fuel consumption as the craft gets bigger. However, once the vehicle being considered is to operate over land as well as over the sea, too large a craft would become embarrassing from the point of view of control and ease of movement. Technically it was found that the best compromise is obtained by designing a craft to carry up to four tanks. This has the added advantage of flexibility of range since, by replacing one tank by fuel, a tactical force of three tanks can still be delivered to a destination at extreme range.

(b) *Hover height.* The craft is supported by a cushion of air. In order to keep such a craft stable its cushion has to be of reasonably low height in proportion to its length and breadth. In order to clear waves and obstacles a designed hover height of 8 ft was considered to be the minimum practicable. The 8 ft hover height will allow the craft to ride waves of 16 ft. Since the hover height is limited to between  $1/15$  and  $1/20$  of the craft's plan dimensions (equivalent diameter), an 8 ft hover height requires a craft of at least 120 ft in equivalent diameter. It so happens that this leads to a design of craft whose maximum payload is four tanks.

This then was decided upon as the payload and results in a tank carrier of considerable size, as will be shown later, but even if the payload were only one tank these craft would not be significantly smaller. It was now necessary to decide upon the military characteristics or performance.

### MILITARY CHARACTERISTICS

These would normally be decided by the War Office and in fact considerable research was necessary on the probable performance of a hovercraft of the size envisaged both over sea and land. At the same time, the type of routes likely to be encountered had to be considered. The characteristics decided upon at this early stage of the study were found to be reasonable and in the final design the craft was judged to have met these requirements.

### OUTLINE MILITARY CHARACTERISTICS

#### *Role*

To provide rapid transportation for the main battle tank over long distances the following characteristics are required in order of priority: load, ocean-going capability, cross-country mobility, range, speed, and reliability.

#### *Load*

Each load must be a tactical one. Therefore each craft must carry a minimum of three tanks over its maximum range. In addition, the lift of tanks in one phase is one squadron of sixteen tanks, but these need not be carried in one craft.

#### *Ocean-going capability*

The craft should be able to negotiate seas up to the following conditions:—



*Desirable.* Beaufort Wind Scale, Force 7 (28–33 knots) and wave heights up to 16 ft.

*Essential.* Beaufort Wind Scale, Force 6 (22–27 knots) and wave heights up to 12 ft.

A reduction in speed is acceptable.

#### *Cross-country mobility.*

*Obstacles.* In order to clear foreseeable obstacles, the craft should be capable of the following hover heights:—

*Desirable*, 10 ft. *Highly desirable*, 8 ft. *Essential*, 6 ft.

The 6 ft clearance will normally allow the passage of the craft over man-made or planted agricultural obstacles, most river banks in all seasons, and small ridges and clefts. It is not required to negotiate mountains, forests, or built-up areas.

*Gradients.* The craft should be capable of climbing a gradient as follows:—

*Desirable*, 1 in 10. *Essential*, 1 in 15.

Reductions in speed to surmount such gradients are acceptable. The craft must be capable of maintaining its course across transverse gradients of the same order.

*Turning.* The route chosen for the craft to satisfy its other characteristics should not be unduly limited by its turning capability at speed. A reduction in speed to aid steering is acceptable provided that the average speed for the journey is not badly affected.

#### *Range*

The range of the craft laden should be: *Desirable*, 3,000 miles. *Essential*, 2,000 miles.

The hover height of the craft can vary with the terrain to give the optimum performance of the craft.

#### *Speed*

The speed of delivery of the tanks to their destination from a base must show a substantial improvement on present or foreseeable methods. The average speed of the craft over land or sea over its maximum range must be a minimum of 50 mph.

#### *Reliability*

The engines should each have a life of not less than 1,000 hours between major overhauls.

### STRUCTURE

The craft should be capable of withstanding the forces incurred when: hovering, resting on roughly levelled ground, or floating on the sea and withstanding sea conditions:—

*Desirable.* Beaufort Wind Scale, Force 6 (22–27 knots) and wave heights up to 12 ft.

*Essential:* Beaufort Wind Scale, Force 5 (17–21 knots) and wave heights up to 10 ft.

*Loading and unloading* which should be accomplished as quickly as possible and in not more than half an hour. The craft should be capable of covering 8,000 miles without the replacement of major assemblies or any maintainance beyond the capabilities of the crew.

#### *Control and operation*

Attention should be paid to the ease of control and operation of the craft by the minimum number of a trained crew.

*Passengers*

The craft should have essential accommodation only for the crews of each tank carried for a maximum period of 36 hours. Extra accommodation for 50 per cent replacement tank crews is, however, desirable.

*Cargo*

The full load of supplies and ammunition normally carried by the tanks may be stowed elsewhere in the craft whilst in transit.

*Protection*

No armoured protection is required. Protection for load and personnel against the effects of sea, weather and winds at speed is required.

## PART II—THE BASIS OF THE DESIGN

There are four types of Ground Effect Machine (GEM) or hovercraft, namely the Leva pad, the Plenum Chamber, the Labyrinth Seal and the simple Momentum Jet Curtain (Fig 1). The Leva pad and Plenum Chamber operate at only a few inches above the ground and so are unsuitable. The Labyrinth Seal is a complicated machine and would lead to engineering difficulties in achieving its principles in three dimensions. The team, therefore, concentrated on the simple Momentum Jet Curtain.

*Basic principles.* Air is drawn in by a fan and expelled in an annular jet curtain around the periphery of the craft and inclined towards its centre. Large quantities of air at relatively low pressures are used. The air fills the space under the craft until the "cushion pressure" is reached. The cushion pressure now turns the jet near the surface (Fig 1) and equilibrium is reached when the inward force due to the change of momentum from one direction to the other balances the outward force exerted by the cushion pressure. The cushion pressure also acts on the base of the craft and the surface over which it rides, thus providing the lift. Power must also be provided for propulsion either combined with the lift or separately.

*Cushion pressure.* A typical plot of cushion pressure against the diameter of a circular craft shows that an increase in pressure means a decrease in size (Fig 2). However as the pressure rises the power required for lift increases rapidly. The power needed for propulsion does not vary much because the effect of having a smaller craft is offset by the greater momentum drag induced by the higher pressure drawing relatively larger masses of air through the fans and ducting.

*Hover height.* This has already been discussed and the effect of height variation on the power required for lift and propulsion is shown in Fig 3. This graph also shows how the air flow required, and therefore the size and weight of the ducting and fans, increases with height. It is clear that for power economy the craft should operate close to the ground.

*Planform.* This is a word which combines both the shape and area of the craft. This area was calculated from the cushion pressure and the All-up Weight (AUW) as shown in the notes to Fig 4. Hovering performance is best with a circular craft, but at speed an elongated one creates less air resistance. Hence a compromise must be made. Fig 4 also shows how lift power varies with planform, the power factor here is a measure of the efficiency of the shape in hover, taking a circular craft as 1. It was considered that a length/width ratio of 1.5 was a reasonable compromise.

TYPES OF HOVERCRAFT

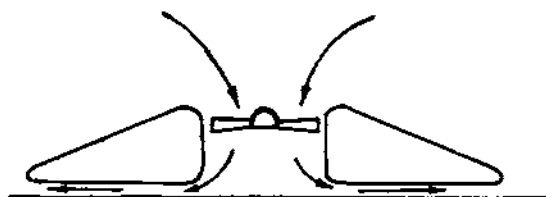

Air bearing

Ford Ieva  
pad

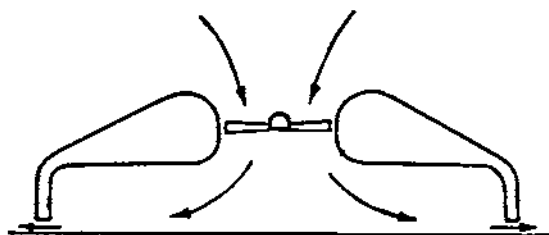

Plenum chamber

Curtis Wright  
air car

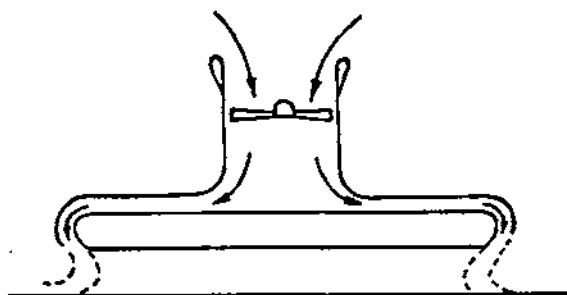

Momentum curtain

SR.NI  
hovercraft

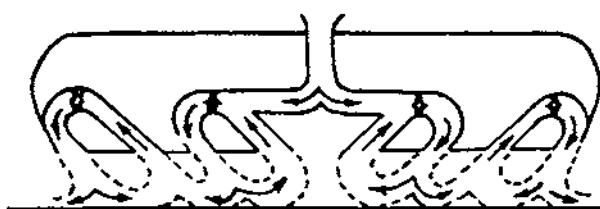

Recirculation

Labyrinth seal  
Weiland  
proposal

Figure 1. Various Lifting Systems for GEMs

*Speed.* As the craft speed increases the lift power decreases slightly due to ram effect, but due to drag forces the propulsion power increases substantially. Fig 5 shows the over-all power increase and the corresponding fuel consumption. It is noticeable that a substantial increase in power occurs at speeds greater than 75 knots.

*Ratio of: All up weight/Fuel weight.* These two variables are interdependent:—

$$\begin{array}{rcccl} \text{AUW} & = & \text{WS} & + & \text{WF} & + & \text{WP} \\ \text{All up weight} & & \text{Structure} & & \text{Fuel} & & \text{Payload} \\ \text{(fixed or variable)} & & \text{Depends on:} & & \text{(fixed or variable)} & & \text{(fixed)} \\ & & \text{(cushion pressure, planform, load)} & & & & \end{array}$$

In this exercise the payload was fixed at four tanks (say 200 tons). As this equation has two possible variables, numerous combinations of AUW and WF were possible in the search for the optimum craft. Based on the experience of Saunders Roe the payload was taken at a conservative figure approximating to 30 per cent AUW. This led to an AUW of some 600 tons.

*Weight breakdown.* Fig 6 illustrates how the weight breakdown varies with cushion pressure for a 600 ton craft. In order to carry a reasonable proportion of fuel a relatively high cushion pressure is required.

#### SELECTION OF OPTIMA

The next step was to consider the power requirements from the equations for different speeds, hover heights and cushion pressures. A sample of the carpets prepared is illustrated for two speeds at Fig 7. It shows how markedly power requirements increase for an increase in hover height or cushion pressure. A glance at the military characteristics at this stage reminded the designer of the need to achieve a good range and that this requirement had priority over speed. Fig 8 (a) shows how the range is affected by cushion pressure and hover height. The best range appeared to be achieved using a cushion pressure of 90 lb/ft. However, remembering the large increase in power required for an increase in cushion pressure (Figs 2 and 7) it is clear that a small sacrifice in range (say 100 miles in 3,000 or 3 per cent) will reduce the installed power needed to maintain maximum hover height from about 80,000 hp to 65,000 hp.

These factors led to the selection of 75 lb/ft as the optimum cushion pressure. Similarly, in the lower graph (Fig 8 (b)) 75 knots appeared to be an economical cruising speed.

*Structure* (for general arrangement see photo). The main problem was to provide a base of the requisite area for the cushion to act upon and to spread the concentrated loads of the tanks. In addition such a structure had to sustain point loads when resting on the ground and to support engines and other weights on its periphery. Other needs were to carry and place any load combinations at or near the centre of gravity and to produce a structure which would resist bending induced by wave motion. It was also important to produce a streamlined aspect to reduce drag. The team finally decided to build the craft round a central "bridge" which would act as the craft's backbone and to use subsidiary cross members to spread the load over the base. The planform chosen was that of two semi-circles joined by straight portions (Fig 13). The front section was extended to form a bow and to reduce spray and rear and front loading doors were provided each end of the "bridge".

PARAMETERS

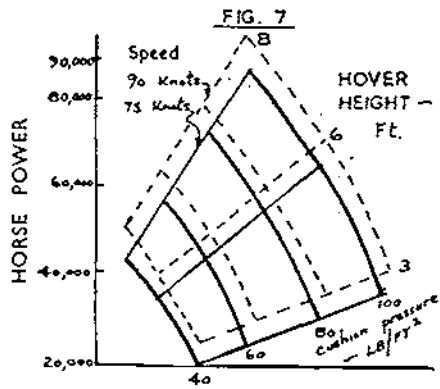
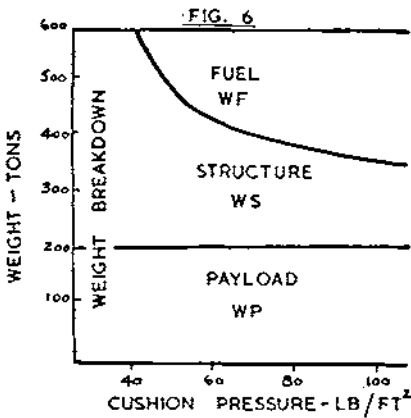
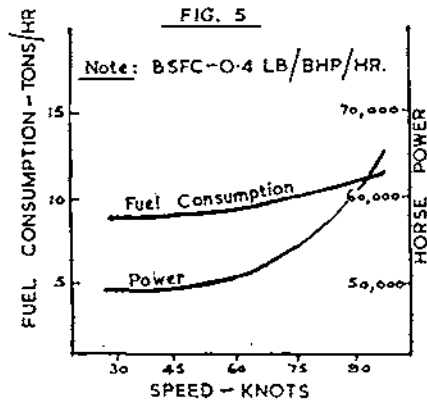
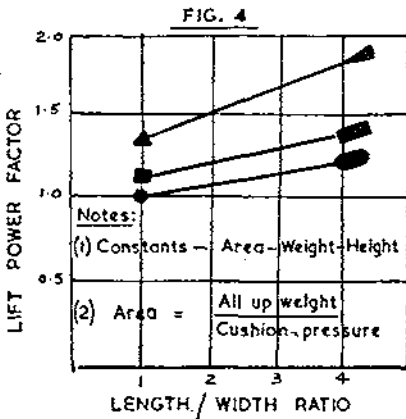
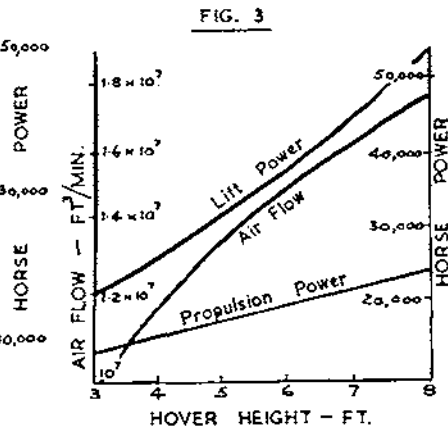
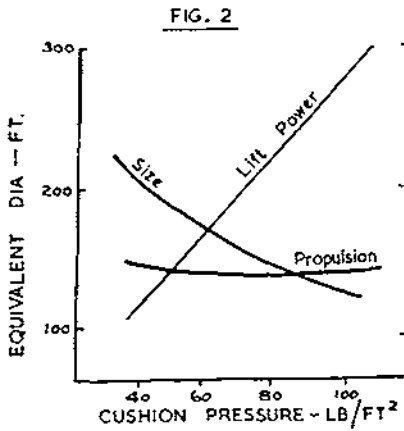

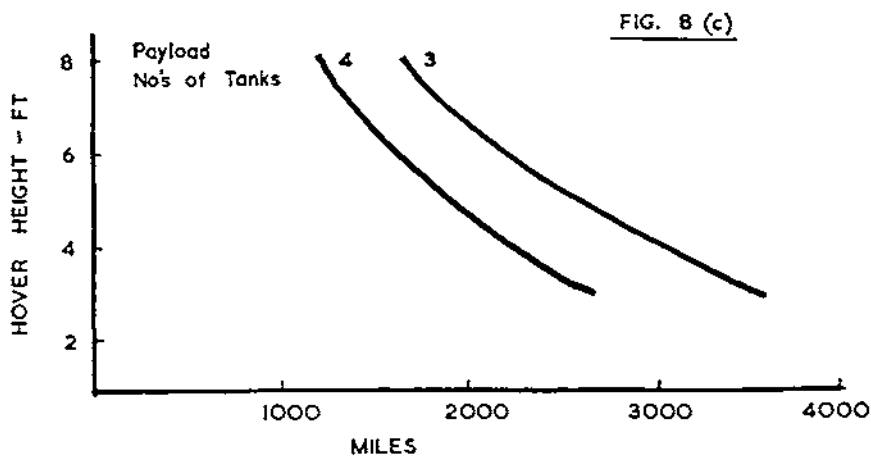
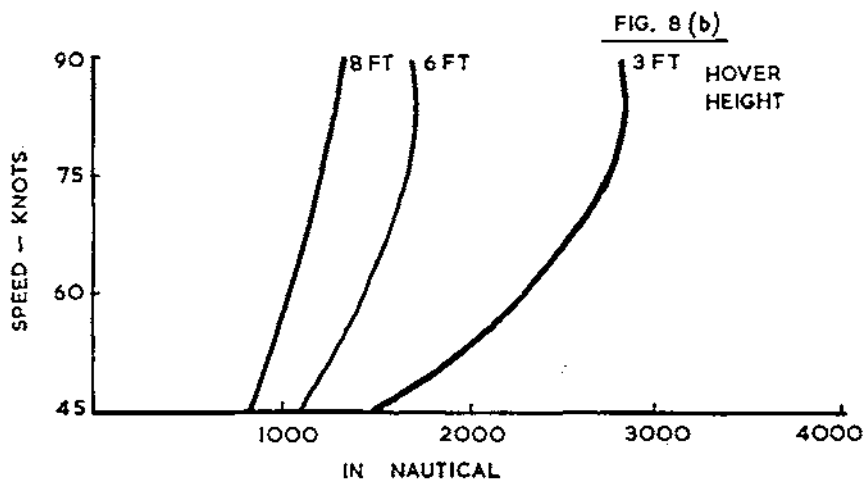
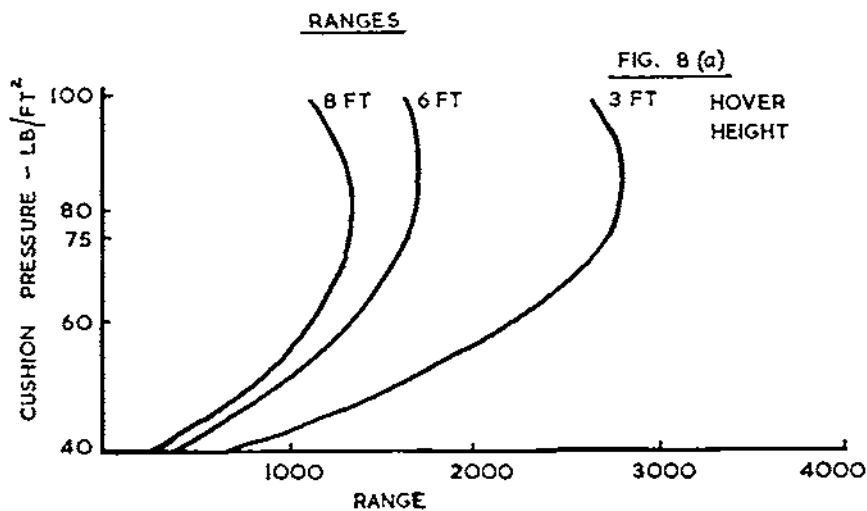

SURFACE EFFECTS

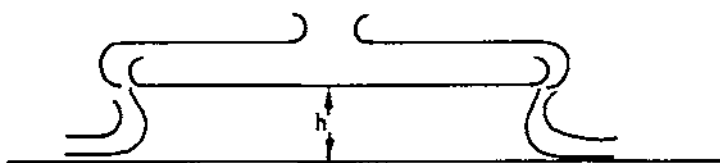

(a) At Zero Forward Speed Over Land.

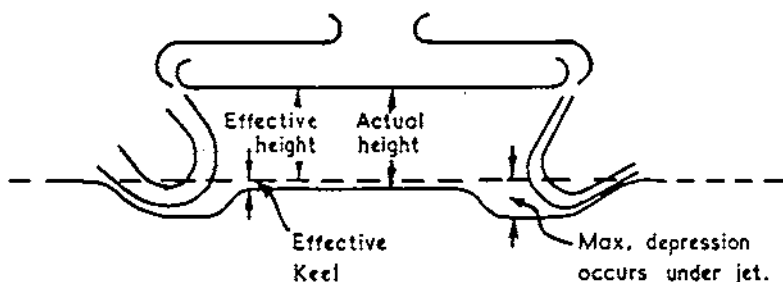

(b) At Zero Forward Speed Over Water.

Fig. 9. Configuration of Surface.

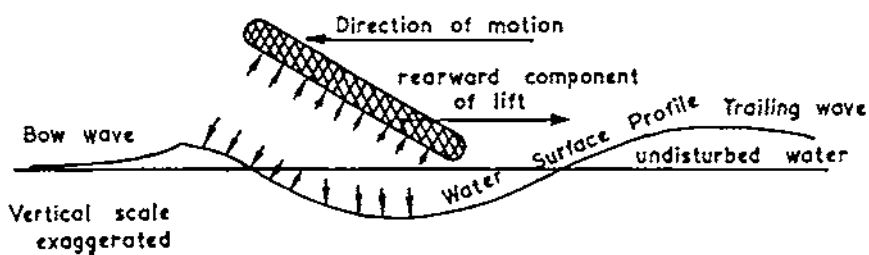

Fig. 10. At Speed Over Water.

STEERING AND CONTROL

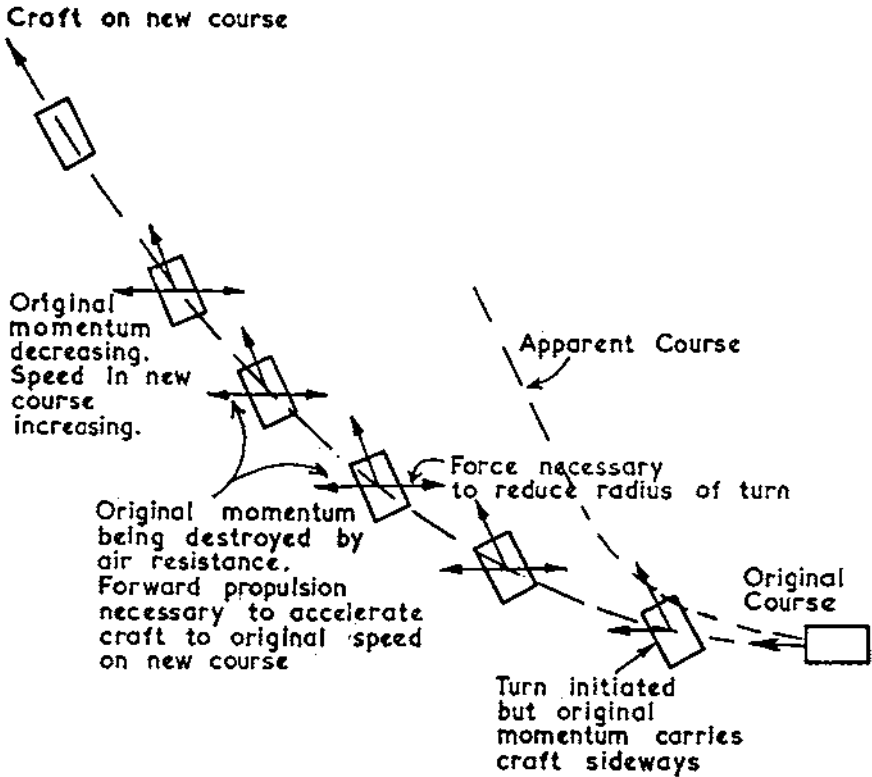

Figure 11. The Principles of Turning.

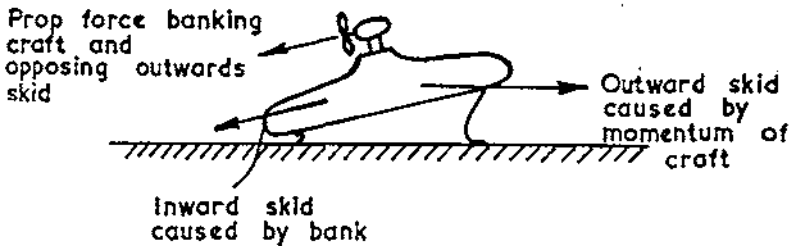

Figure 12. The Effect of Banking.



The over-all dimensions worked out to be about 200 ft in length and 125 ft in width.

*Lift power.* After weighing up the pros and cons of mounting one enormous fan centrally with only one set of controls but with acres of resultant ducting, against many smaller fans mounted around the periphery with easy ducting problems but difficulties in controls and weight distribution, the team chose ten engines mounted around the periphery of the craft. These were to be a well-known make of gas turbine engine driving horizontally mounted fans. The jet annulus was inclined inwards at 30 degrees to the horizontal and the jet vanes on the straight side sections were movable, thereby enabling the side parts of the curtain to be deflected forward or aft to a maximum of 45 degrees. This would enable part of the lift power to be available for propulsion or for turning the craft.

*Engine details.* 7,000 shaft hp max, 5,500 shaft hp continuous cruise and 0.4lb/bhp/hr BSFC.

*Propulsion power.* Four similar engines driving reverse pitch airscrews were mounted as shown in the photograph. The two rear engines were fixed and on fins, almost the width of the craft apart. The front two were mounted on pylons on the top of the structure and were capable of swivelling to assist in control.

*Steering and control.* One of the most serious problems in all large GEMs will be steering and control. Such machines all have a tendency to skid sideways after they have been turned, rather like a box skidding on ice. This is not surprising as one of the main conceptions of a GEM is to reduce surface friction when at speed. This skidding is not too serious over water, where the air cushion causes a depression (particularly under the peripheral jet) which acts as an air keel (Fig 9). Additionally, when at speed over water, bow and trailing waves are generated and the craft assumes a slight inclination (Fig 10). These conditions are particularly noticeable at a speed dependent upon the craft's dimensions which normally occurs between 10 and 25 knots. This is known as the "hump" speed. Slowing the craft to this speed increases the drag and assists in control over water.

Overland no such natural braking is possible, so propulsion power must be made available, not only to counter inertial forces and the effects of gradients, but also to accelerate the craft in its new direction after a turn has been made. In simple terms the problems are firstly to turn the craft and secondly to stop it skidding sideways (Fig 11). The craft would be turned by means of rudders on the rear fins and by varying the thrust on the rear propellers. To prevent or reduce sideways skid at small angles and at slow speeds, the power on the inner side of the jet would be decreased, so the craft would slip inwards. For large angles of turn say above 20 degrees or at high speed the front engines would be swivelled so that their thrust opposes the skid (Fig 12). For close manoeuvring the swivelling vanes of the straight portion of the jet annulus could be used.

It is emphasized here that these are only provisional ideas and final methods employed would be the results of research and development. As is well known, except for a Russian claim to have built a 400-ton hovercraft, machines of this size have not so far been built. Furthermore, no practical tests on manoeuvring large craft over the sea, let alone overland have yet been undertaken.

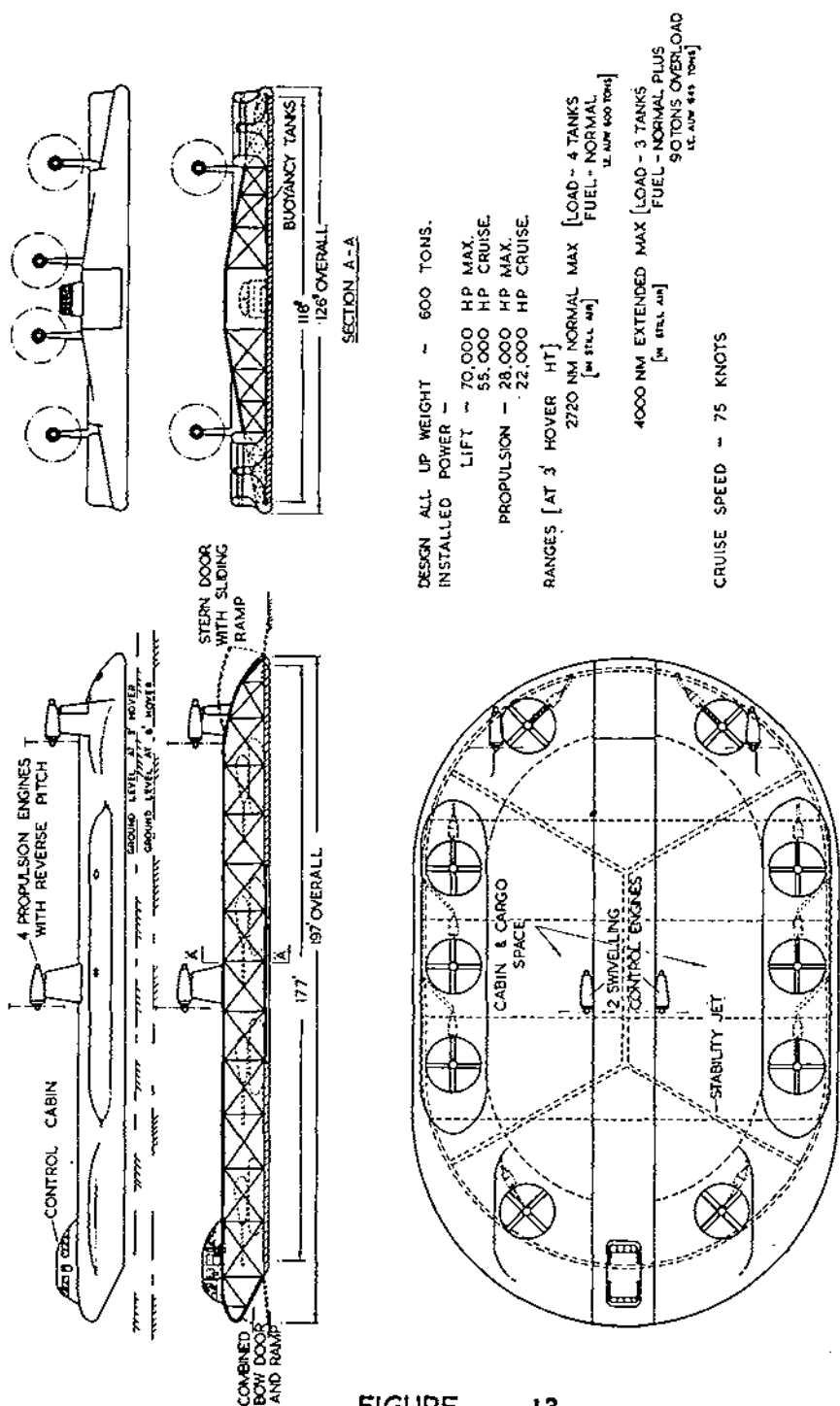

DESIGN ALL UP WEIGHT - 600 TONS.  
 INSTALLED POWER -

LIFT - 70,000 HP MAX.  
 55,000 HP CRUISE.  
 PROPULSION - 28,000 HP MAX.  
 22,000 HP CRUISE.

RANGES [ AT 3 HOVER HT ]  
 2720 NM NORMAL MAX [LOAD - 4 TANKS  
 FUEL - NORMAL  
 12,000 400 TONS]  
 [M STILL AIR]

4000 NM EXTENDED MAX [LOAD - 3 TANKS  
 FUEL - NORMAL PLUS  
 90 TONS OVERLOAD  
 12,000 400 TONS]

CRUISE SPEED - 75 KNOTS

FIGURE 13.  
 THE PROPOSED DESIGN.

*Plan of the craft.* The exercise did not require a detailed design. What was produced was an outline design which was considered to be feasible. The essential features of this design are shown on the plan at Fig 13.

The vertical stability jets shown were designed to confine the cushion under the craft into sections in order to compensate for any sudden tilts of the craft or temporary loss of one portion of the curtain due to crossing ditches or undulations.

There are three cargo spaces, the vehicle "bridge" which is wide enough to enable most types of wheeled vehicles to be loaded two abreast and one general cargo space each side of the "bridge".

*Performance.* The following figures were calculated:—

Maximum payload, 200 tons; normal fuel, 193 tons; maximum speed, 100 knots; cruising speed, 75 knots.

Maximum hover height with full fuel tanks, 8 ft; maximum waves cleared, 16 ft.

*Still air ranges.* Fig 8 (c). shows how these will vary with the hover height and payload. The substantial range margin achieved over the military characteristic requirement was designed to compensate for adverse headwinds and the need for extra use of power to achieve the maximum hover height when clearing obstacles.

*Hover height.* Fig 14 shows how this can be increased as the fuel is used, the normal case when a long oversea leg occurs before overland movement.

*Hill climbing.* Fig 15 shows the calculated performance. Transverse gradients of about half these values can be crossed without side-slip and the speeds would be reduced proportionately.

*Ditch crossing.* Assuming that the craft approaches the ditch or river normal to its course at a reasonable speed rough calculations indicate that the limits can be safely assumed to be as follows:—

For a deep nearly semicircular shaped ditch.

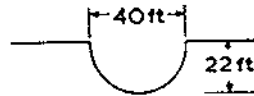

For a shallow trapezoidal ditch with 10 ft high banks.

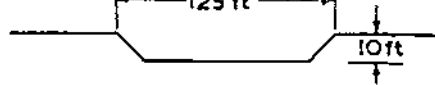

At these limits the craft would be about to ground on the far bank. For ditches of lesser dimensions the craft will suffer a loss of height temporarily.

Calculations indicate that the ditch crossing ability is not affected by speed to any marked degree, provided that full lift power is used.

*Craft refinements.* It is clear that in a study of this type all the detailed refinements of the craft cannot be fully considered. If such a craft were to be built it would be logical to expect improvements and extra fittings in order to obtain optimum performance. Basically such improvements would be aimed at reducing structure weight, improving fuel consumption and increasing the hover height. Furthermore, the natural hazards of dust and spray would have to be allowed for and consideration given to the corrosive effects of such dust, spray and salt water on the structure and engines.

In outline possible improvements to the craft might include:—

(i) Development of special metals and alloys to lighten the main structure and to safeguard it from electrolytic action.

(ii) Development of existing engines, probably of the gas turbine type, to achieve a low BSFC.

(iii) The adoption of devices to increase the hover height. These are likely to include the fitting of solid sidewalls to the craft for operation over water thereby saving lift power. In the case of the craft under consideration such sidewalls would have to be retractable for overland use. Another plan is to fit a flexible skirt round the periphery of the craft to help contain the air cushion, thereby giving the main structure extra clearance for the same jet characteristics. High obstacles could deflect the front portion of the skirt, pass under the craft and emerge through the rear portion, which could be slotted for this purpose. For operation over water only it may be possible to suspend jet deflectors below the craft. These would be so shaped that the air tending to be forced outwards by the cushion pressure would be deflected back towards the centre of the air cushion. A craft combining sidewalls with deflectors in the fore and aft parts of the periphery would be more economical over water, but both sidewalls and deflectors would have to be retractable for overland use.

(iv) Development of air intake filters. In order to achieve long engine life it would be essential to use some means of filtration for dust and spray. This is a matter for research and development, but probably some form of inertial separation of solid and liquid matter from the mass of air passing through the engines would answer this requirement.

#### CONCLUSION

This feasibility study indicates the general lines upon which such a craft could be designed. It would appear that the general configuration outlined, together with the estimates of performance given, lead to a craft which can satisfy the military characteristics already discussed.

#### PART III—MOVEMENT

A craft with an operating height around 8 ft will allow movement over sea in all but the worst conditions and should allow reasonable movement overland.

*Movement over sea.* The dominant factor here is wave height. The proposed craft should be able to operate with waves up to about 16 ft. Any direct relationship between wave height and wind speed is complicated by factors such as the position of land masses, but in general the craft should be able to operate with wind speeds of about 30 knots (Beaufort Scale 7). For example, information from the Institute of Oceanography indicated that the craft could operate for 99 per cent of the year in the Mediterranean, the Persian Gulf and the Red Sea, and for 95 per cent of the year in the Indian Ocean except during the monsoon season from June to August when operating periods might be reduced to 50 per cent of these months.

*Overland Movement.* Here the major limitations are obstacles such as river and canal banks, embankments and similar hazards exceeding 8 ft in height, buildings, trees, power and telegraph lines, clefts, depressions in the ground, rivers and wadis. Such obstacles would tend to obstruct the craft's movement or lead to grounding of the craft due to the air cushion being allowed to leak away. Maximum gradients should not exceed between 1 in 5, and 1 in 10; and equally important, in view of the length of the craft are

## PERFORMANCE AND EFFICIENCY

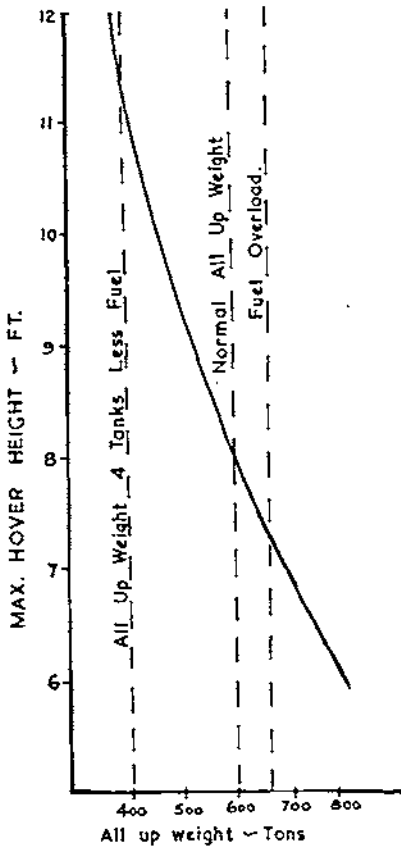

FIG. 14. MAX. HOVER HEIGHT VARIATION WITH AUW

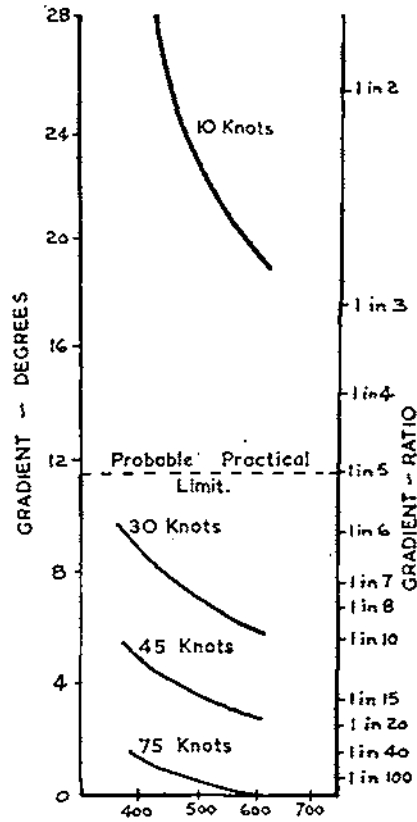

FIG. 15. HILL CLIMBING VARIATION WITH SPEED

sudden changes in gradient which would cause grounding at its ends or in the middle. Such changes in gradients should not exceed 1 in 10. Poor manoeuvrability, as discussed under Steering and Control, would make it difficult for the craft to follow a course over a winding river, or to take a tortuous route round obstacles. It follows that in general terms movement will be impossible in mountainous or hilly country, in heavily built up areas and over forests.

On the other hand movement would be possible over flat plains and desert, over rivers, river valleys and deltas, over inland waters and over marsh, bog and salt flats.

Naturally with an operational move problems will occur in navigation and in the detailed following of the best route. However, in the future it is expected that aids to navigation would include radar, mounted in the craft and capable of producing a strip display of the ground ahead of the craft,

an automatic position plotting device and radio beacons en route. The beacons could have been dropped by reconnaissance aircraft.

Helicopters which could be carried on the craft and which could precede it overland could place coloured markers indicating the best approach for the craft to follow when traversing the worst obstacles.

#### CONCLUSION

GEM movement over open seas presents no special problems. Quick delivery of tanks over sea routes will be possible in all but the worst weather conditions. Most routes chosen could offer opportunities for the craft to seek shelter on land should bad weather conditions be encountered. Alternatively the team was advised that the craft could float in sea conditions much worse than those quoted as requirements in the military characteristics.

GEM movement overland depends on good information, rapid planning and speedy clearance techniques, so special aerial reconnaissance, photography and air photo interpretation techniques would have to be developed.

Long-term planning of possible routes will be of the greatest importance.

Rapid assessment of engineer tasks and mobility of the Field Engineers clearing the obstacles will be of paramount importance.

The use of an aerial crane carried on one craft, and capable of carrying one tank over relatively short ranges (say 100 miles) would be of great value in achieving the final lift, should the craft be delayed by a large obstacle.

Since a GEM is not tied to roads or rivers and can choose any suitable route, many obstacles could be by-passed. However it is clear that on no route could they be entirely avoided. Some clearance would, therefore, be necessary and with this in mind, consideration was given to the likely engineer tasks involved.

#### PART IV—ENGINEER SUPPORT

*General.* For the type of operation envisaged speed is vital and the time available for route clearance will inevitably be short and a period not exceeding about 12 hours is probably all that can be allowed for clearance. The size of the force will be small so few Sappers are likely to be available, a field squadron being probably the most that could be expected. The above factors mean that the number and size of the obstacles that could be cleared would be limited. This emphasizes the need for careful route reconnaissance and selection and the fact that engineer participation in these will be necessary right from the initial planning stages of any operation.

*Obstacles.* Full details of the number and type of obstacles to be cleared can only be found by detailed reconnaissance. This has not been possible for this study and all that can be done is to examine the types of obstacle that are likely to be met and the methods available for clearance.

*Trees.* Trees and similar objects, such as telegraph poles, are likely to prove the most frequent obstacles, particularly over more developed countries. Clearance of extensively wooded areas would present too big a task with the limited time and resources available. Small clumps of trees, belts of trees along features such as rivers or canals and trees in defiles would, however, need to be cleared. Some clearance methods suggested are: demolition by explosives, pushing or winching by tractor and cutting by power saws. For trees up to 1 ft in diameter clearance by medium or large tractor

would be the quickest method but as the tractors would have to be carried by air, or by the craft itself, and the groups of trees would be widely scattered the use of a tractor for this type of clearance would be unusual. Demolition of trees presents no particular problem. It can be achieved by the following methods:—

(a) *Prefabricated necklaces.* This method is rapid but expensive in explosives. For a 1 ft diameter tree up to 2 lb of plastic explosive may be required. As clearance parties and equipment would have to be air dropped or helicopter borne, weight is an important consideration and it may not always be possible to carry sufficient explosive for this method.

(b) *Borehole charges.* With present methods this is slow but requires less explosive. A 1 ft diameter tree requires only 6 oz. This would be the best method if some device could be developed for the rapid preparation of boreholes.

Some possible methods for the rapid preparation of boreholes could be by using miniature beehives weighing around 6 oz, some form of bolt-firing gun or by manpack powered augers. A further development might be the use of an all-in-one device where a charge is blown into the centre of the tree and detonated. The use of power saws will probably be limited due to the time required to cut down each tree, particularly those over about 10-in in diameter. One advantage, compared with the use of explosives, is their fixed weight irrespective of the number of trees involved.

*Buildings.* The use of the craft over heavily populated areas would be avoided wherever possible, but in defiles, at exits from beaches and from watercourses clearance of buildings may be necessary. Clearance could again be achieved by the use of explosives or tractors, but the same considerations, regarding the movement of tractors, apply. Tractors are unlikely to be used except where a sizeable group of buildings is involved. For demolition, concussion charges would have to be used as the time required using borehole charges would be prohibitive. Concussion charges are uneconomical in the use of explosives but as the number of buildings involved would be small this would have to be accepted. To demolish a simple type of building of internal volume 2,000 cu ft would require 15–20 lb of plastic explosive.

*Rocks.* Large rocks or small rocky outcrops may have to be cleared. The best method would be to use beehives and borehole charges.

*Embankments.* Earthmoving would be required when exits from beaches, banks of waterways or other ground features in the form of a step exceed the operating height of the craft. Clearance required would be the lowering of the lip of the bank to about 7 ft with a slope back to the original ground level not exceeding 1 in 10. Such a task, with its short haul and down hill working, is ideal for tractor with bulldozer blade. Even a light-wheeled tractor, which can be air dropped, could move up to 150 cu yds of ordinary earth per hour. In the future it should be possible to air drop heavier tractors. Ballastable tractors with a lighter basic machine might be developed and give higher outputs. The use of wheeled tractors would be desirable for ease and speed of movement between obstacles. Explosives might be required to speed up the work by breaking and loosening the ground particularly where it is very hard. Some material would also be thrown down from the tip of the bank reducing the dozing work required. Techniques similar to those used for digging by explosives would be suitable. By such methods 35–40 cu yds could be quickly loosened by 6 lb of plastic explosive. Estimated times for

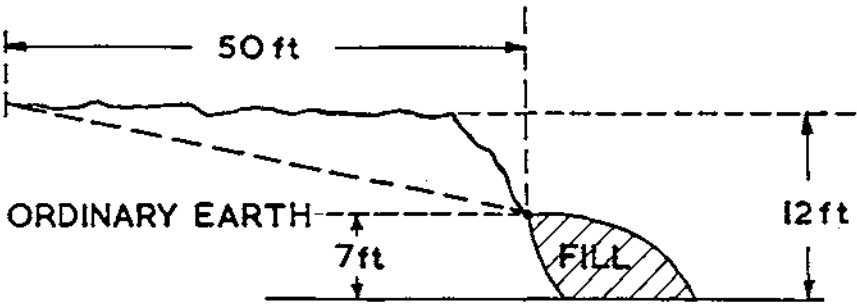
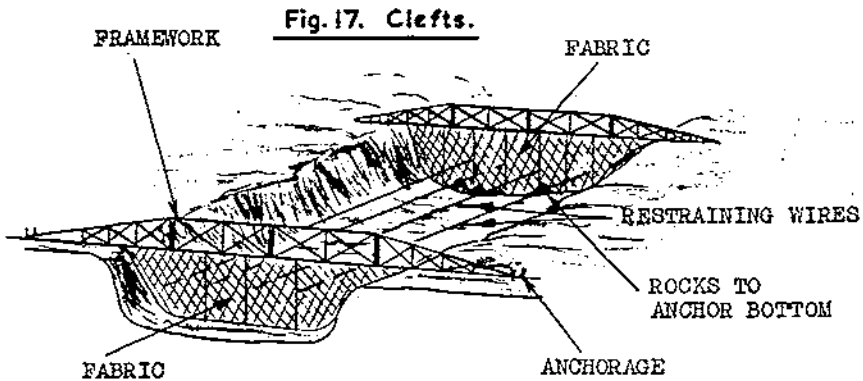

**Fig.16. Embankments**

an exit 130 ft wide from a river as shown in the sketch at Fig 16 are:—

<i>Tractor</i>	<i>Timings (hours)</i>	
	<i>unaided</i>	<i>with explosives</i>
Light wheeled .. .. .	14	10
Medium wheeled .. .. .	10	7
Heavy tracked .. .. .	6	4

Times for a heavy tracked tractor are included because one might be carried on a craft for an emergency movement.



**Fig.17. Clefts.**

*Clefts.* Where the craft has to pass over ravines, wadis, small rivers with high banks and similar surface indentations air will leak from the cushion and the craft may ground if the cleft is too large. Unless the cleft is too wide it may be that all that will be required will be two “plugs” placed a craft-width apart. For large clefts a combination of the earth-moving as required for embankments and plugging may be needed. Formation of earth plugs by bulldozer would be the easiest method as the total quantity of earth required will not be large. Other methods for plugging will be needed when a tractor is not available. One possible method, shown in Fig 17, would be to use some form of strong fabric screen supported on a light metal framework anchored at each end. The screens could be restrained from blowing outwards by wires joining them together. The pressure to be contained is low and the fabric



and framework for quite a large cross-section could be light and should be economically airtransportable. Such fabric plugs would be particularly useful for emergency movement of the craft.

*Effect of GEM on engineer effort.* The methods outlined above give some idea of the work required to open up GEM routes. This would appear to be very much less than the work required from engineers to open routes for other means of tank transport. Not only does the building of high classification bridges take time, but requires heavy stores brought to the bridging site along lines of communication that may well be disrupted or congested. Road clearance and restoration requires time and earth-moving equipment. If a GEM can be employed in a theatre, therefore, it should effect a considerable saving in engineer effort. This might well be a most important factor especially over areas of nuclear activity, where engineer effort will be much in demand.

It is also worthy of note that route clearance for a GEM in addition to normal engineer tasks in progress at the same time does not impose an additional unduly heavy load on the Engineers. Providing reconnaissance and planning has been carried out in detail, and care taken to select the best route, the engineer support required for the GEM should be small and the task achieved quickly. The employment of a GEM would then not only deliver its load of tanks faster than other means, but would do so with less engineer support. This factor might even justify the use of a GEM to transport stores across the communications zone when terrain permits.

#### CONCLUSION

The methods which the Engineers could use for GEM route clearance would be little different from those required for many other tasks but the techniques required for speedy reconnaissance, very rapid planning and the deployment and control of small parties spread over possibly hundreds of miles would need to be developed. Special training would be required.

### PART V—COMPARISON OF HOVERCRAFT WITH CONVENTIONAL TANK TRANSPORT

*Position in relation to normal transport.* Fig 18 shows the position of hovercraft with respect to ships and aircraft, and compares the weight of each vehicle with its speed. It can be seen that the hovercraft conveniently fits in between the ship and the aircraft. It bridges the gap between light, fast, small load-carrying aircraft, and heavy, slow, large load-carrying ships. As a tank is a large aircraft load and a small ship load, it would seem that the hovercraft type of vehicle would be logically suited for its transport.

#### AIRCRAFT

At present the movement of a main battle tank by existing aircraft or helicopters is not feasible. In the future it may be possible for this to be achieved by rotary wing aircraft, but this would only be over relatively short ranges.

*Fixed wing aircraft.* The transport aircraft at present in service with NATO forces is the American Douglas C.133 Cargomaster. Brief performance figures of this aircraft are as follows:—

Capacity payload, 100,000 lb (approximately); range with this load, 1,600 miles; speed, 300 mph.

At first sight this would seem to answer the requirement, but for this aircraft, as for others, a tank produces too much concentration of load. The

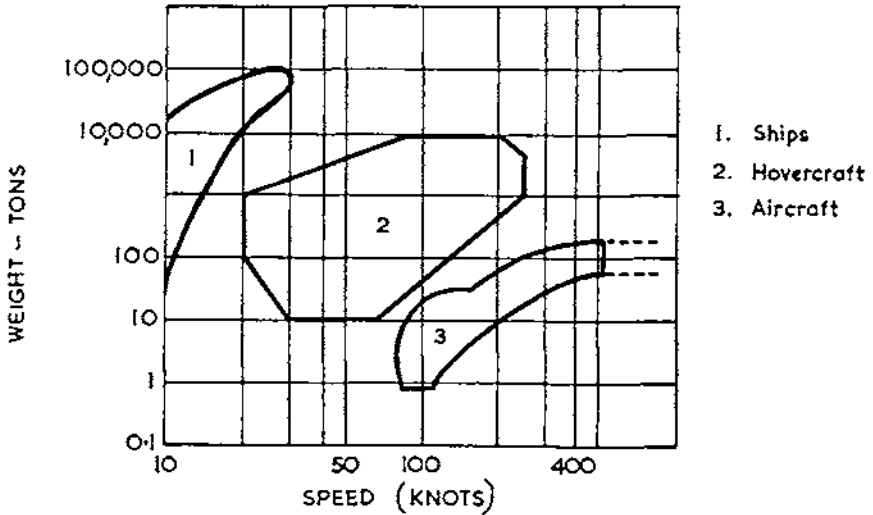

Fig. 18. Position between Ships & Aircraft.

results of this on the aircraft would be excessive stresses in the airframe (as it is impracticable to spread such a load over the length of the fuselage) and excessive stresses in the aircraft flooring. This latter effect is partly due to the fact that the load of the tank is concentrated over its track spuds in a non-uniform manner on a metal surface, and partly because, even if the load were spread over the whole floor area, the floor supports would still be overloaded. Further, such a load has to have its centre of gravity correctly positioned. This may not be possible if the tank occupies most of the loading compartment. In flight "G" loadings of up to "3G" may occur due to sudden vertical movements of the aircraft in rough weather. Under these circumstances a concentrated load, such as a tank would tend to drop through the floor because of the sudden overloading.

These points have been explained in detail as they are common problems for loading a tank in any aircraft. In the case of the Douglas C.133, the manufacturers and USAF have specified 76,000 lb as the maximum weight allowable for transporting a tracked AFV, which is only about three-quarters of the weight of a main battle tank.

Runways are required for landing and take-off and these must be of extremely solid construction (approximately 12 in of concrete). Although the Douglas C.133 has a short take-off and landing capability, this would still entail a major construction problem. Thus the largest existing transport aircraft is unable to move the main battle tank under any circumstances.

Although the scaling up of such an aircraft, as discussed above, would appear to be logical to improve its AFV lifting capacity, such development is not expected. The structural problems would entail large increases in aircraft weight and power. Also such an aircraft's use would be further limited by the larger runways required. Furthermore, it would entail high development and maintenance costs and would not achieve an advantage over the

C.133 in its normal roles. The cost of such aircraft would also be very large compared with a GEM as envisaged.

*Rotary wing aircraft.* One of the world's largest machines is the Sikorsky S.60 helicopter crane. This is limited to a maximum capacity of about 8 tons and a range of up to 100 miles. Considerable development is being undertaken in the form of giant "rotary wing" flying cranes to lift large loads over short distances. By 1970 it is possible that such an aircraft might exist capable of lifting one main battle tank, the possible characteristics of such a craft being as follows:—

Load, 100,000 lb (approximate); range, 120 miles; fuel consumption, 10 tons; speed, 100 mph.

This being so, it is not unreasonable to anticipate that by 1970-5 a rotary wing aircraft might be capable of lifting a 50-ton tank over a range of 100-200 miles at perhaps a slightly increased speed. The heavy fuel consumption when carrying such a load may show this range to be optimistic, but long ranges could be achieved unladen.

### CONCLUSION

At present aircraft do not compete with the GEM in this field. It may well be possible to use rotary wing aerial cranes in support of a GEM in surmounting obstacles, or for short range tank lifts to complete a GEM journey.

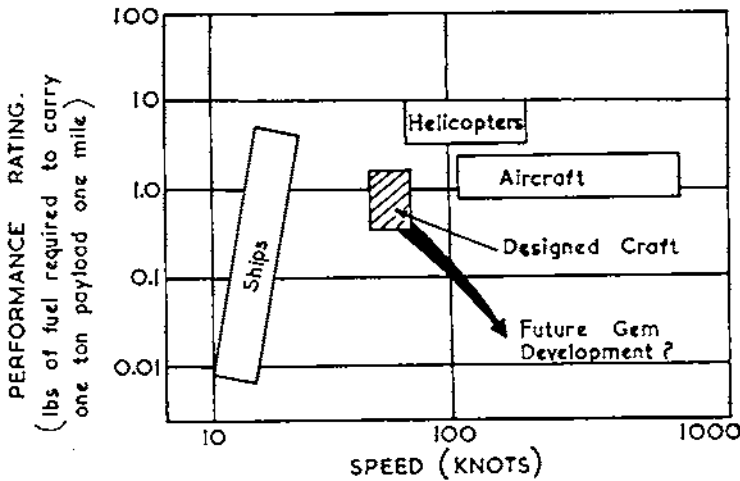

Fig. 19. Comparison of Efficiencies

### SHIPS

The diagram at Fig 19 illustrates how the efficiency of GEMs compares with conventional forms of transport, the yardstick being the weight of fuel in lb necessary to carry 1 ton of payload for 1 mile. The less fuel required the greater is the efficiency. As can be seen, the ship can give the best efficiency rating for the transport of heavy loads such as tanks. It does, however, represent slow transport. The advent of the new Commando Assault

Ship may be thought to offer the best speed of ship borne tank transport. Certainly the port facilities required for normal ships can be by-passed, the tanks being delivered to a beach from the Assault Ship, but its speed would be about one-quarter that of a GEM and the problem of covering the distance from the beach to where the tanks may be needed operationally inland still persists. The use of a GEM over a typical operational route would appear to result in cutting the time taken by the best possible maritime and land transport by three-quarters.

## PART VI—USE AND ECONOMY

This article so far has been concerned only with studying the feasibility of such hovercraft as tank carriers for use during periods of cold or limited war. The resulting design is an expensive piece of equipment, which may not be justified if limited to this one role.

*Uses.* It is clear from the performance details given earlier that by varying the payload of the craft the carriage of bulk loads too heavy for aircraft could be rapidly achieved in a strategic role. Allowing for adverse wind and sea conditions some typical military loads which could be lifted 4,000 miles are:—

Fourteen 3 ton vehicles (fully loaded) or, seven 10-ton vehicles (fully loaded) or, twenty-eight Scout cars or, twelve armoured cars and twelve Scout cars.	}	Here the payload is <i>not</i> a maximum and extra fuel is carried
--	---	--

If shorter ranges are used the payload could be increased. All these loads could be carried at a cruising speed of 75 knots. No other transport can deliver such bulk payloads over such distances so quickly.

It follows that strategic movement of reserves to overseas theatres or within a theatre could be swiftly carried out. The craft is particularly suited to the carriage of vehicles and urgently needed supplies from a base to a forward area with a minimum of cargo handling and a quick turn-round capability. Furthermore, land movement over formerly impassable territory such as marshes, etc is possible. In nuclear warfare, where widespread damage has occurred to ports, roads and airfields, GEMs may well offer the only effective alternative to present day conventional transport.

*Economy.* The efficiency rating of GEMs has already been discussed and illustrated in Fig 19. Operationally the cost of a war, with all its side effects, even if it is only a small one, can never be fully assessed. What is certain is that the cost of prevention, however large, will always be less. In analysing the economics of a craft, such as the GEM, this must be taken into account. If it can quickly deliver its load to a trouble spot in time to prevent a war, when conventional means cannot do so, it will have proved to be worthwhile.

In addition, the financial cost of an operation of the type envisaged depends largely on the time of arrival of an effective force at a trouble spot. The effectiveness of this force may well depend on its having armour support. In general terms, the sooner a containing force arrives and the stronger the force the shorter will be the length of the operation. The cost can be measured in terms of unit operational days. This is a major point and will greatly outweigh the initial cost in assessing the financial economics of such a tank carrier.

*Cost of one craft.* Estimates of the cost of a hovercraft have been worked out. These costs are very heavy for small craft but decrease proportionately for larger ones, where shipbuilding "know-how" in the use of light alloys for members of reasonable size can be used in place of the more intricate structures necessary in small craft.

Ships made of light alloy can cost about £500 per ton. An aircraft can cost about £20,000 per ton. Estimates for hovercraft are difficult to gauge, but for a craft of the size envisaged £5,000 per ton might be of the right order. The cost of the GEM craft envisaged might be between one and four million pounds. This compares favourably with estimates for the Fairey "Rotodyne"—£1 million and the Short "Brittanic"—£2 million, neither of which is capable of carrying one main battle tank.

### CONCLUSION

The exercise showed that the GEM as a tank carrier is both feasible and economical. It can be limited in mobility by terrain but could still operate over large areas throughout the world. Undoubtedly the best surface for it to travel over is the sea, where only severe wave conditions should limit its use. Further detailed study of terrain is required to determine fully the mobility of the craft.

It is considered that such a craft should be designed to carry four main battle tanks as its optimum load. A configuration for a craft carrying such a load would be of the following main dimensions: about 200 ft long, 125 ft wide and 15 ft high.

In the time of delivery of a force of tanks to a destination far from their base, the GEM will effect a considerable saving over other methods. Its range, whilst tactically loaded, could be of the order of 2,000 nautical miles, but this will vary with the payload chosen and with the sea, wind, wave and terrain conditions on a particular route.

The technical penalties for producing a craft for military use over sea and land are mainly caused by the high overland hover height and the long ranges required. These combined lead to a large craft size and to the installation of more power than would otherwise be needed.

To enable the craft to travel over land new techniques for route reconnaissance and engineer effort would have to be developed.

If the movement of such a craft were restricted to the sea it would still go a long way to providing armoured support quickly.

Finally, what the exercise tried to assess impartially was how rapid movement of the main battle tank could best be achieved. It did not try to sell the GEM principle, or the designed configuration, as being the ideal answer, and every other known form of transport was considered. It seems clear that the GEM type of craft offers advantages in time and engineer effort over existing methods of tank transport. At present, only the overland movement seems to offer major problems, but these should be capable of solution. What is also clear is that craft of the type discussed would be of use commercially as well as militarily. In fact such craft are occupying the attention of civilian firms in this country today.

# The Present Status of the Small Power Reactor

By MAJOR A. A. T. HISCOCK, BSC(ENG), RE

THE papers which have so far appeared in the *RE Journal* on nuclear power<sup>1, 2</sup> have not dealt in detail with the small reactor and it is my intention to review the present state of development in this field in which there is no doubt a considerable military application. Many of the advantages and disadvantages of military power reactors were reviewed by Captain Aylwin-Foster<sup>2</sup> and I do not propose to discuss them here except to remark that in the past few years a very considerable amount of practical design and operational experience has been built up, particularly in the United States.

## THE SITUATION IN THE UNITED KINGDOM

It should be clearly appreciated that the United Kingdom has up to the present applied very little effort to the technology of the small power reactor as such, although this may well change as a result of interest in marine propulsion. A "small" power reactor is usually considered to be a reactor producing less than about 50 MWe. Although the UKAEA, has not, for various reasons put much development effort into reactors of this size, there are a number of commercial concerns which are now interested in this type of reactor. The reason for the interest is the commercial one that there seems to be a promise of exports to areas where fuel costs are high. An examination of the activities of the companies concerned shows either:—

1. Agreements and design studies made in conjunction with United States firms with actual experience of the reactor types offered, or
2. Design studies made without a specific United States link.

In both cases nearly all the firms already have experience of some aspects of nuclear engineering but readers without contact with the nuclear world should be careful to note that the difference between a design study and an actual reactor on the ground and generating electricity may be many millions of pounds. There is thus a great advantage gained by those firms with close links with American companies who have reactors working.

The power reactors or power reactor experiments at present working in the UK are the large UKAEA reactors at Calder Hall, Chapelcross and Dounreay, although the CEGB reactors at Berkeley and Bradwell should be commissioned this year.

## THE UNITED STATES EFFORT

It is still generally true that small power reactor development is being carried out for the Services rather than for civilian use. The United States Army Nuclear Power Programme (ANPP) deals with small land-based power requirements up to 10 MWe on behalf of the three Services and is directed by a Colonel of the US Engineers who has a dual role. He is Chief of AEC Army Reactors Branch and also Special Assistant for Nuclear Power to the Chief of Army Corps of Engineers. Military requirements above 10 MWe are dealt with by direct development of civilian programmes.

The propulsion of warships, aircraft and rockets are of course dealt with

under separate programmes. The extent of these is shown by the following figures:<sup>3</sup>

	Research and Development			Construction		Total	
	Cumulative to 30.6.60 \$ millions	1960	1959	1958	Cumulative to 30.6.60 Addi- authorized		
Army reactors	32.3	12.0	9.4	5.7	7.3	7.8	15.1
Aircraft reactors including missiles, etc.	509.6	112.9	102.5	81.9	58.3	59.4	137.7
Naval reactors	556.8	88.8	90.6	97.3	193.8	33.4	227.2

By comparison the total production and research allocation for the British Defence Forces in 1961-2 is £658,850,000, say \$1,850,000,000.<sup>4</sup>

#### PROGRESS IN THE USSR

The climate and geographical location of many regions of the USSR make the exploitation of both large and small reactors a matter of economic and military importance. Russian activity in the large reactor field has been reasonably widely published and there is also information available on some aspects of small reactors.<sup>5</sup> These include a pressurized water reactor of 1.5 to 2 MWe, direct cycle gas-cooled reactor experiments perhaps similar to the American GCRE described later in this paper and a number of boiling water reactors and experiments in the 50 MWe range. The same reference indicates activity in the field of aircraft nuclear propulsion. Mention must be made of the atomic icebreaker *Lenin* which has three pressurized water reactors each of approximately 44,000 hp steam generating capacity.<sup>6</sup>

#### THE PRESSURIZED WATER REACTOR

The first practical and successful small power reactor was that installed in the USS *Nautilus* in 1955. This was an enriched uranium pressurized water reactor. The technology of this reactor type has been much developed leading to the present United States fleet of thirty-five nuclear submarines in service or under construction<sup>3</sup> a number of nuclear powered United States and Russian surface ships and our own first nuclear submarine.<sup>7</sup> There are also land based power reactors including the US Army APPR.1 (now SM1). See Appendix I.

The pressurized water concept was selected by the USAEC, for its prototype small power reactor of 22 MWe for "supplying efficient and reasonably economic power for various isolated areas in this country and abroad".<sup>3</sup> According to one report<sup>8</sup> this has now been abandoned for economic reasons.

#### THE BOILING WATER REACTOR

The next step forward from the PWR has been in the direction of boiling water reactors. These have evolved because of:—

1. Simplicity of the direct steam cycle.
2. Lower operating pressure for a given steam temperature.
3. Higher thermal efficiency.

The first boiling water reactor experiment (BORAX 1) was only made in the United States in 1955. The problems seemed formidable but enormous progress has been made and much confidence gained which has not been entirely dispelled by the recent accident to SL1.<sup>9</sup> The ultimate objective is of course the generation of nuclear superheated steam at pressures and temperatures comparable to modern conventional plants. BWRS in small sizes were until recently represented by SL-1 (formerly ALPR) which gave

3 MW (thermal) and which was a prototype of the PL1 (200 KWe) and PL2 (1,000 KWe) pre-packaged power plants. The function of those plants is to power radar equipment and heat adjacent offices and barracks at remote Arctic installations and decisions were taken in 1960 to use PL2 reactors in this role at sites in the Antarctic.

### THE DIRECT CYCLE GAS COOLED REACTOR

Despite the great and continuing achievements of the PWR and the great potential of the BWR the high temperature direct cycle gas-cooled reactor seems to have the best chance of satisfying the need for a portable power source on land, sea and in the air (including "aerospace"). The US Army gas cooled reactor systems programme includes four principal projects.<sup>10</sup> These are:—

1. Design construction and operation of Gas-Cooled Reactor, Experiment 1.
2. Studies directed towards the design of an advanced backup experimental reactor (GCRE II).
3. Design, construction and operation of the gas turbine test facility.
4. Design development, construction and operation of MLI (Mobile Low Power Plant I), a gas-cooled closed cycle gas turbine of 3–500 KW.

The MLI achieved criticality in March 1961, and is a prototype of reactor which must inevitably assume great importance. The design requirements of the plant are set out in the following summary:—

1. Electrical output—300–500 KW, 2,400/4,160 volts three phase 50–60 cycle.
2. Ambient temperature range —65° to +100°F.
3. Weight—40 tons max 15 tons max pkg.
4. Design lifetime—10,000 hr between fuel changes. 50,000 hr over-all plant.
5. Radiation—15 mr/hr at 25 ft forward direction 24 hr after shut down.
6. Size—as dictated by certain sizes of US railcars, trailers, and aircraft.
7. Field procedure—installation time 12 hrs. Requirements—preparation for relocation from aircraft 6 hrs.

These requirements have been substantially achieved and the whole reactor system weighing 82,000 lb can be carried in a Douglas C133A, for a distance of 2,000 miles. Alternatively the system can be carried in three Douglas C124's or three Lockheed C130A's.

The reactor is a heterogeneous water moderated type, fueled by enriched uranium dioxide. The reactor heat is transferred to the working fluid as it flows past the elements and the fluid (nitrogen) leaves the reactor at 1200°F, passing to the turbine which operates in a closed cycle system.

### GAS-COOLED REACTORS FOR AIRCRAFT AND MISSILES

Aircraft and missile reactor programmes have a vital importance which the United States and also, no doubt, Russia appreciate and have acted upon. In the United Kingdom one or two civilian firms have devoted some effort to consideration of the problems involved but this effort has remained small. I have no doubt that, although the figures are readily available, very few readers of this paper will have appreciated the vast expenditure which has been incurred by the United States on these programmes. Nor will all have appreciated the determination of the United States to carry their air



power supremacy into the field of "aerospace power". In the words of General Thomas D. White, Chief of Staff, US Air Force:<sup>11</sup>

"The military exploitation of airborne nuclear propulsion will provide a significant increase in our future deterrent capability—an increase which must be realized if this capability is to remain effective. Thus the support of this effort by the USAF, is in keeping with our constant goal—the preservation of peace through the unquestioned pre-eminence of this nation's aerospace power."

The US programme for aircraft reactors has been in two parts<sup>3</sup>, that for manned aircraft and that for unmanned vehicles. For the former there were until March 1961 two lines of approach under active investigation, involving the direct and the indirect cycle. For unmanned vehicles there are three programmes; nuclear rocket propulsion (Rover), nuclear ramjet propulsion (Pluto) and nuclear auxiliary power (Snap). Both the manned and unmanned parts of the programme continued on a substantial scale until March 1961 when President Kennedy severely cut the manned aircraft programme.<sup>12</sup>

The initial objective laid down by the US Department of Defence, was to develop a nuclear propulsion system capable of powering an aircraft with relatively conventional aerodynamics in the 500,000 lb weight class at Mach 0.8 to 0.9 at approximately 35,000 ft and with a potential power life of 1,000 hrs. A preliminary design of an airframe compatible with both direct and indirect cycle system was accomplished. The direct cycle approach was represented by HTRE3, a reactor designed to operate with two modified J47 turbojet engines and which completed its first testing programme in December 1960. The indirect cycle was being approached through a 10 MW (thermal) high temperature experimental reactor and this was clearly further away from a flyable reactor than HTRE3. However, President Kennedy has now<sup>12</sup> ruled against continuation of both these aircraft programmes although some research will continue.

The Rover nuclear rocket propulsion programme was separated from part of the aircraft reactor programme in 1960 and is now part of the space propulsion reactor programme, whose objective is to develop reactors and related nuclear technology for the propulsion of space vehicles. In June, the President gave this programme his full personal official endorsement and nuclear rocket development must now be regarded as a most important part of America's national effort.

This programme is operated jointly by the National Aeronautics and Space Administration (NASA) and the Atomic Energy Commission. The main part of the Rover effort has been the development of the Kiwi series of non-flyable experimental reactors.

High pressure hydrogen gas has been used as coolant-propellant in this series up to Kiwi A3 and a new series (Kiwi-B) will now proceed, involving the use of liquid, rather than gaseous, hydrogen as the coolant propellant. This is a requirement for a flyable system.

The first flight test in the Rover programme is put at some time after 1965 and activity on research and development for a nuclear rocket engine (project Nerva) is beginning as also study of problems of flight testing nuclear systems (RIFT—Reactor in Flight Testing). Those interested in the details of Rover should refer to "Hearings before the Committee on Science and Astronautics of the US House of Representatives. 87th Congress. US Government Printing Office 1961".

The Snap programme has as its first objective the development of electrical power needed to operate the equipment and instrumentation needed in space payloads. The requirement may exceed 1 MW by 1965. In addition to this however, electrical propulsion systems are now under study which depend on the development of very light weight long life electric power generating systems. The feasibility of this is under investigation as part of the current Snap 8 programme.<sup>13</sup> In the Pluto programme for nuclear ramjet development there was recently a successful test of a Pluto reactor and it has been stated that this may lead to a speed up of development of the whole system.

#### UNITED STATES STUDIES OF REMOTE MILITARY POWER APPLICATIONS

In 1959 the USAEC issued a contract to Kaiser Engineers for the study of remote military power applications. This was first published in January 1960, revised July 1960, and consists of a series of reports evaluating the economics of construction and operation of nuclear power plants at certain sites during 1968-70.<sup>14</sup> The power requirements vary from 5 to 40 MWe. The sites chosen were those for which the cost of nuclear power is most nearly economically competitive with the cost of conventional power. The sites selected were:—

Okinawa 1	40 MWe
Okinawa 2	40 MWe
Guam	20 MWe
Thule, Greenland	25 MWe + 150,000,000, BTU/hr of heat
Norad, USA	7 MWe
Asmara	5 MWe
Supersage USA	5 MWe
Nike-Zeus USA	5 MWe
Inchon	10 MWe
"Atlantic Barge"	20 MWe
McMurdo Sound 1	5 MWe
McMurdo Sound 2	6 MWe
Byrd Station Antarctica	800 KW—Supplementary report
Pole Station Antarctica	—

The reactors selected for the various locations were limited to those, or modifications to those, having existing designs, i.e. which are now being or have been built. In fact the recommendations made are that either pressurized water or boiling water reactors should be used. In certain cases it was found that a floating power plant offered a reasonable proposition. These are:

Thule  
Inchon  
Atlantic Barge

These three would have a specially built or a conventional ship's hull. In addition a "mobile marine platform" of pontoon type is recommended for Guam.

Three sites were evaluated and eliminated from further consideration. These are:—

<i>Site</i>	<i>Location</i>	<i>Reason for elimination</i>
"Pacific Barge"	Pacific ocean area	Power requirement of 5 MWe made a nuclear power plant economically unfavourable for a power barge.

Panama	Canal zone	Nuclear power much more costly than conventional power due to low fuel costs.
Hokkaido	Japan	Power requirement below 5 MWe.

The economic considerations underlying the study are complex and based upon assumptions which are applicable to the sites chosen and to the US Government but not necessarily applicable elsewhere or to the UK Government. In general however, the following are the most important factors when considering the cost of nuclear as against conventional power:—

- (a) The size of the nuclear reactor itself.
- (b) The size of the power plant.
- (c) The cost of fossil fuels.

It must be remembered however that economic considerations are not necessarily the most important and this particularly applies to a site such as NORAD (North American Air Defence Command Operations Centre, Colorado).

An indication of costs can be obtained from the summary below, taken in a much simplified form from the main Kaiser report.

- (a) Size of plant: 5 to 40 MWe.
- (b) Total project (i.e. capital) costs at 1963 escalated figures:—
 

Nuclear	6 to 24 million dollars
Conventional	3 to 12 million dollars
- (c) Unit power costs at 1963 figures:—
 

Nuclear	10–57 mills/KW hr
Conventional	11–102 mills/KW hr

(d) Total project cost plus total operating, maintenance and fuel costs for a twenty-year period:—

*Total nuclear costs substantially lower*      *Total nuclear costs slightly lower*

Okinawa	Guam
Thule	Nike-Zeus
McMurdo Sound	

*Total nuclear costs substantially higher*      *Total nuclear costs slightly higher*

Norad	Atlantic Barge
Super-sage	Korea
	Asmara

One of the results of the Kaiser Engineers study was the award in August 1960 to the Martin Company of a contract for design construction and test operation of a prepackaged 1500 KWe power plant to be shipped in November, 1961 to McMurdo Sound. In addition to this, as a result of a supplementary report, construction of nuclear plants was authorized for Byrd and South Pole sites, also in Antarctica. In these cases the requirement of 800 KW was well below the general limit of 5 MWe taken for the main study. For Byrd station, costs are as follows:—

	<i>Nuclear</i>	<i>Conventional (diesel)</i>
Total project costs	\$9,600,000	\$3,100,000
Power cost in mills/KW hr (assuming twenty-year plant life)	126.0	353.9

### THE UNATTENDED NUCLEAR PLANT

Although a reactor has a very great military potentiality because of the fact that it does not need provision of fossil fuels, there is nevertheless a considerable maintenance backing required at the present time. This backing is greater than would be required for a conventional power station and both the operation and maintenance of the plant require high grade personnel. The unattended nuclear plant which will produce power at a constant rate for say, a year without refuelling or attention of any kind is therefore particularly attractive. A report entitled "Feasibility of an unattended Nuclear Power Plant" has been prepared by Oak Ridge National Laboratory for the USAEC.<sup>15</sup> This is a study of the feasibility of constructing a 1 MWe nuclear power plant capable of operating for one year in four year's time (1964). It is considered by the authors that the objective is most likely to be obtained by extreme simplification of an existing reactor and a pressurized water type has been chosen for the application because of extensive experience with it and because it appears readily adaptable for simplification. The power plant suggested has hermetically sealed primary and secondary systems and all control systems except the turbine governor have been eliminated.

### ROYAL ENGINEERS AND THE REACTOR

The nuclear power reactor is a system basically simple but in practice of great complexity. If designed or operated badly or carelessly, it can be catastrophically dangerous. More and more power reactors of all shapes and sizes are being developed and some of them will play an important part in military deployment and operations.

In this the Royal Engineers should play its part and indeed will fail in its duty if it cannot do so. It is of importance to realize that this cannot come about by sending officers or men on short familiarization courses. Nuclear technology covers a vast and difficult field and it will be necessary to build up over a number of years a body of officers and technicians with knowledge and experience of reactor design, construction, maintenance and operation. The building process must start now. One of the first steps should be to ensure that a proportion of young officers reading for degrees do so in fields from which reactor technology develops naturally. This will probably involve a higher proportion of officers reading mathematics and pure science and must be supported by a considerable change in emphasis in the technical training of certain Warrant Officers, NCOs and tradesmen.

### APPENDIX I

#### SUMMARY OF THE UNITED STATES ARMY REACTORS PROGRAMME

	<i>Designation</i>	<i>Type</i>	<i>Remarks</i>
SM1	Stationary medium power plant 1	PWR	1855 KWe. Fort Belvoir Va.
SM1A	Stationary medium power plant 1A	PWR	1640 KWe plus 38 million BTU hr of steam. At Fort Greely, Alaska.
SM2	Stationary medium power plant 2	PWR	Originally for Nike-Zeus but not required and will be used for R and D and to complete design.

PM <sub>1</sub>	Portable medium power plant 1	PWR	Air transportable in 16 cargo aircraft. Intended for Sundance Wyo.
PM <sub>2A</sub>	Portable medium power plant 2A	PWR	1,500 KWe plus 1 million BTU hr of steam. A further development of SM <sub>1</sub> . At Camp Century, N. Greenland.
PM <sub>3A</sub>	Portable medium power plant 3A	PWR	Contract awarded August 1960 for prepackaged 1,500 KWe plant to be shipped to McMurdo Sound in November 1961.
SL <sub>1</sub>	Stationary low power plant 1	BWR	A nuclear explosion occurred in this reactor in January 1961.
PL <sub>1</sub> PL <sub>2</sub>	} Portable low power plants	BWR	Prepackaged versions of SL <sub>1</sub> .
GCRE I GCRE II			
GTF	} Gas turbine test facility	} Gas-cooled closed cycle gas turbine of 3-500 KW	
ML <sub>1</sub>			Mobile low power plant 1
MCR	Military compact reactor		

NOTES

1. PL<sub>2</sub> reactors for Byrd and South Pole sites were authorized in 1960 but funds were not appropriated in that year.
2. 92 military operators had completed one year training courses conducted in conjunction with plant operation on SM<sub>1</sub> at Fort Belvoir by the end of 1960.
3. Further details of the programme are contained in reference <sup>3</sup>.

REFERENCES

- 1 "Nuclear Power Engineering", Lieut-Colonel J. E. L. Carter, *RE Journal*, March 1957.
- 2 "Non destructive military applications of Nuclear Energy", Captain P. F. Aylwin Foster. *RE Journal*, June 1958.
- 3 USAEC. "Major Activities in the Atomic Energy Programs", January-December 1960.
- 4 Report on Defence 1961. HMSO Command 1288, February 1961.
- 5 2nd United Nations Conference on the Peaceful Uses of Atomic Energy. Vol 8, page 580.
- 6 *Ibid*, page 204.
- 7 UKAEA. 5th and 6th Annual Reports. HMSO, July 1959 and July 1960.
- 8 *Nuclear Power*, April 1961.
- 9 USAEC. "Interim Report on SL<sub>1</sub> Incident, 3 January 1961", dated 27 January 1961 and also report in *Nucleonics* for March 1961.
- 10 (a) Army Gas-Cooled Reactor Systems. Program Semi Annual Progress Report to 30 January 1960. Report IDO-28558. (b) AGCRS Program. Report IDO 28550, 16 May 1960. (c) AGCRS Program. Report IDO 28555, April 1960.
- 11 *Nuclear Flight*, edited by Lieut-Colonel K. F. Gantz, USAF, NY, Duell, Sloan and Pearce 1960.
- 12 "*Nucleonics Week*", 30 March 1961.
- 13 *Nucleonics*, April 1961.
- 14 USAEC Reports. NYO 2937 to NYO 9052, 1960.
- 15 USAEC Reports ORNAL-2985, September 1960.

# Joint Services Bomb Disposal

By MAJOR D. W. TOWNSHEND, RE

ALTHOUGH the disposal of enemy bombs has been a Sapper responsibility for twenty-one years, it is a subject known little to the Corps as a whole. In December 1959 Major Hartley wrote an article in this journal describing the present day operational problems in dealing with bombs dropped by the Germans during the last war. It is my purpose to fill in some of the background information leading to the formation of the Joint Services Bomb Disposal School.

The first recorded use of an explosive missile delivered by air, and not fired or thrown by some propellant, was in 1849 when the Austrians used small charges of gunpowder attached to balloons against Venice. The gunpowder was fuze with slow burning wicks and the balloons allowed to drift on a favourable wind over the city. The material damage was negligible but the explosions are reported to have had considerable effect on the morale of the population. There is no record of the disposal of those missiles which failed to explode, perhaps the gunpowder was scattered or dumped in water where it would have been harmless.

The disposal of bombs and sea mines has always been a closely related subject, not only because sailors and sappers traditionally work well together, but also because missiles have arrived, deliberately or accidentally, out of their element. Thus we have the problem of sea mines on land and aerial bombs in the water.

The first instance of actual disposal of sea mines occurred in 1855 during the Crimean war. A large number of Russian contact mines, laid for the defence of their principal harbours at Sevastopol, Sveaborg and Kronstadt, were rendered safe by the British. The fuzes were of an extremely ingenious type, comprising a glass tube filled with sulphuric acid and embedded in a mixture of chlorate of potassium and sugar. The whole fuze was enclosed in an outer tube of lead, the end of which protruded from the mine case. On contact with the hull of a ship the lead tube was bent, breaking the glass tube. When the acid came in contact with the chemicals the resulting heat and flame fired the main charge which consisted of 25 lb of gunpowder. Many Russian mines were recovered and rendered safe under hazardous conditions by teams which probably consisted of Royal Navy and Royal Engineers.

From 1863 to 1905 the Royal Engineer Corps of Submarine Miners were responsible for controlled mining, i.e. mines used for the defence of harbours and fired from the shore. Colonel Colt, of revolver fame, was a true pioneer of controlled mining and in 1849 had succeeded in destroying a moving ship some 5 miles from the land.

An extract from a memorandum,<sup>1</sup> which may be considered as the official starting point from which sprang not only the military system of mines, but also all naval mines and torpedoes in the British Service, and the systematic use of passive obstructions, is recorded below.

"There can be no doubt as to the great power to be derived from the application of floating or submerged mines and artificial obstructions as an accessory of defence against the passage of an enemy's vessels through narrow or comparatively narrow channels; these mines (or torpedoes, as sometimes called) may be made for explosion either by galvanic batteries from the shore or by concussion or collision with the vessel, either of which methods may be useful or preferable under special circumstances. The first would have the great advantage of little or no danger of accidents in storage, removals, or handling even roughly, and would be perfectly harmless to our own ships, which might be in collision with them without the least danger; the objection would be the great difficulty of knowing precisely when the enemy's ship is in absolute contact with them."

At a conference in 1874 it was decided that the Corps of Submarine Miners should do the work connected with the preparation, testing, and firing of the mines, and the Navy should provide the vessels and assist with laying the mines and the water work generally.

A naval history<sup>2</sup> of mines describes two early types of controlled mine which were adopted for harbour defence.

(a) The 500-lb observation mine, fired electrically from the shore.

(b) The 76-lb electro-contact mine.

In the former type, the correct moment at which to fire was established either by direct observation along a line of aiming marks, or by cross-bearing from two observers each provided with a firing key, or by means of a "Depression Position Finder". This instrument consisted essentially of a telescope mounted in a control station overlooking the minefield and fitted with a spring plunger which moved over a set of contact strips as the movements of an approaching enemy ship were followed. These strips were connected to the firing circuits of the mines or groups of mines, the circuit from the battery to the correct group being completed simultaneously with the passage of the enemy ship over that group.

In the electro-contact type, the firing battery could be put "on circuit" whenever it was required to bring the defences to the ready. On being struck by a ship, the mine fired due to the circuit being closed either by the movement of an inertia weight or the displacement of a small quantity of mercury. The explosive charge in both mines was guncotton, adopted by Great Britain in 1870.

The development of minefield clearance is best illustrated from a history<sup>3</sup> of the time.

"This year (1878) there commenced a noteworthy series of experiments carried out jointly by the RN and RE, which yielded much data as to the best way of attacking and defending a mined area, and had an important effect on the future patterns of mining shores."

"For some years previously the Navy, though not developing their mine systems, had given great attention to the methods of clearing a way through minefields, and had evolved three systems, called 'creeping', 'sweeping', and 'countermining'. The first consists in dragging an explosive creep or grapnel along the bottom till it catches an obstruction; the creep is then hauled tight and the charge exploded, so that if a cable has been grappled it is cut by the explosion. The objection to this system is that the attack is always uncertain as to which mines are connected to the cut cable, and the number of boats and time required to clear a definite area is considerable. Sweeping

is done by two boats with a length of rope or chain hanging between them. The boats drift slowly over a minefield until the sweep catches a mine, which is then either raised or cut adrift by a charge. This method cannot be carried out under artillery fire, and is ineffective against ground mines; it is also very slow. The third method, countermining, is the most effective of all, but requires considerable preparation and a large expenditure of stores. It consists of firing in a mined area a series of large charges, designed to damage or destroy all defensive mines within a certain radius. Containers usually contained 500 lb of guncotton, and were exploded at distances 60 yds apart, this having been found by experiment to ensure the destruction of all mines lying between any two containers."

Before the First World War the Royal Engineers were responsible for the disposal of sea mines near the coast. Floating mines were invariably sunk by rifle fire directed at the buoyance chamber and left to lie harmlessly on the sea bed. The same treatment would be equally effective today to deal with miscellaneous aerial pyrotechnics (flame floats, smoke floats etc) which are frequently found floating in the sea. Effective yes, but needless to say this treatment is not advocated even where positive identification can be made.

The first recorded use of bombs dropped from aircraft was in 1911 when the Italians bombed Tripoli. There was no fuzing system, the bomb simply consisted of containers filled with nitro-glycerine which exploded on impact. Nitro-glycerine is so unstable that its use in such a way was a widely hazardous procedure. There was certainly no disposal problem because all bombs exploded—many long before they reached the enemy lines!

During the First World War there was no bomb disposal problem as such. Bombs dropped from airships and aeroplanes were small and designed to go off on impact with the ground. Those that did not explode were invariably found on or near the surface and were collected up, together with other stray ammunition, and treated as "blinds".

Immediately prior to and after the commencement of the Second World War, the Ministry of Home Security, working through the Civil Defence, was responsible for clearing up after air raids and this included unexploded bombs. In spite of the development both in the design and size of bombs, and the intricacies of their fuzing systems, it was still thought that any bomb which failed to explode would be found in a harmless condition on, or very close to the surface of the ground. They could be dealt with by the existing Civil Defence organization along with the other after effects of air raids.

This supposition was extraordinary for two reasons. In the first place, as far back as 1932, the Germans had applied for a patent in every civilized country for "electric time and impact fuzes for projectiles and the like". Details of electric fuzes, which were fitted to a bomb, and designed to go off at a predetermined time after it had landed, were available from HM Patents Office. In the second place, what were then comparatively modern bombs, had been dropped during the Spanish Civil War. Of the bombs which did not explode, nearly all penetrated several feet into the ground and some detonated several hours later. Probably in the general panic and confusion which prevailed this lesson was never grasped but, whatever the reason, it left this country with no organization or equipment for dealing with the thousands of bombs dropped by the Germans which failed to explode.

It soon became clear that the civil authorities were quite unable to cope with the menace of the unexploded bomb and it became a Service responsibility.



The division of responsibility, for dealing with unexploded bombs in the U.K. was, and still is, broadly as follows:—

- RN All bombs below high water mark and enemy bombs on RN property.
- Army Enemy bombs above high water mark and all bombs on Army property.
- RAF Allied bombs above high water mark and all bombs on RAF property.

Responsibility for consideration of, and general administration of, the scientific problems of unexploded bombs, was vested in the "Unexploded Bomb Committee". On this committee sat the Directors of Bomb Disposal of the three Services, representatives of the Home Office and Ministry of Home Security, together with certain scientific advisers drawn from Government and independent sources. No apparatus had been developed for production or even trial on a live bomb and time was of paramount importance. An account of the working of this committee is given below.

"The organisation, however, was on such lines that action on any decision could be taken immediately without any further reference for technical or financial approval. From its inception and throughout the whole period, complete co-operation, collaboration, and team spirit existed between every member, Service and civilian, of the closely knitted group of users, scientists, designers, and producers, who, collectively and individually, spared no effort in those most difficult and anxious times of the impending and actual blitzes. Nevertheless, looking back, it is amazing that leeway was so rapidly made up under conditions of extreme secrecy. Great encouragement was given by the close personal interest of the Prime Minister and Minister of Supply in this work. Mr Churchill wrote: 'The rapid disposal of unexploded bombs is of the highest importance. Any failure to grapple with this problem may have serious results on the production of aircraft and other vital war material. The work of the Bomb Disposal Squads must be facilitated by the provision of every kind of up-to-date equipment. Priority A should be allotted to the production of the equipment and to any further requirements which may come to light'.

"A small, carefully selected group of scientists and engineers, each a volunteer, was formed into a Headquarters Branch. They considered each new problem as it arose, assisted in the recovery of new fuzes and explosives, co-ordinated research and development, tested prototypes and production models. All important tests were made on the full scale, using filled enemy bombs: Urgency and the fear of unknown 'scale-effect' simply did not permit the usual procedure of research and development. All practicable safety precautions were taken, but hazards were unavoidable and accepted."

The problem of organization to meet this new commitment was more difficult for the Army than the Royal Navy or Royal Air Force, who each had a suitable organization in existence which could be expanded. The Admiralty Mining Establishment at HMS Vernon consisted of a number of civilian scientists and torpedo officers. These men were entirely familiar with our own sea mines so it was natural that the techniques for dealing with bombs on Admiralty property should be combined with this. The RAF Empire Air Armament School had been established for some years. It taught

armament artificers recognition, arming and fuze design. Rendering safe was part and parcel of the armourer's trade.

In the case of the Army there was no suitable establishment which could be expanded to meet current needs. Traditionally the Royal Army Ordnance Corps had always dealt with shells and stray ammunition. However, it quickly became apparent that unexploded bombs might end up many feet under the ground. This would require a considerable amount of excavation and revetment, in fact it was an engineering task, demanding units with specialized tradesmen. The RAOC had no such units and the commitment was handed to the Royal Engineers. Field and construction companies were converted overnight into bomb disposal companies which prepared to grapple with the task. Their task was considerably more difficult than that of the RAF Armourers because the RAF dealt mainly with our own bombs, which they knew about, while the Sappers had to deal with enemy bombs about which little or nothing was known.

Moreover these new bomb disposal companies had no real master. Regimentally they were administered by the Royal Engineers, but at War Office level they were directed by the Director of Anti Aircraft and Civil Defence. They worked in close liaison with the Ministry of Home Security and sometimes received orders from civilian authorities. Their equipment to deal with an unknown hazard was mainly confined to road mending tools and explosives.

It was on these sorry beginnings that bomb disposal was built until it became a credit to the Corps and earned the esteem and admiration of the whole country as the following extract from the official history<sup>6</sup> shows:—

"It was a cold-blooded business. When reports of the arrival of a bomb which had not exploded came in, it was first necessary to reconnoitre to see if it was really there. In a great many cases the original report proved to be a false alarm. Either the object was not a bomb, or in some cases it had penetrated deeply into the ground before exploding and made no crater. Once confirmed, and if the position of the bomb demanded immediate attention owing to the proximity of buildings, etc., which could be damaged, the section moved up and started work. Very frequently excavation was necessary before the bomb could be reached. Penetration up to sixty feet was recorded. This was a 'jumpy' occupation, as any violent disturbance might set the bomb off, and often the soil where the penetration was deepest was such that casing or timbering was required. For this, usually timber (at first) but later steel became available. Once the bomb was reached its type and probable performance had to be determined by inspection. It might be fitted with a delay action fuze which had not run its allotted time. It might be that the delay action mechanism had been put out of gear by the shock of landing, in which case any disturbance might set it in action again. Or it might be a simple contact fuze which had not operated. Later the enemy added all sorts of ingenious complications, the most serious being attachments to the fuze which caused the bomb to detonate if attempts were made to withdraw the fuze. In the early days, before information about enemy fuze markings had been collected and collated for the use of investigating officers, this inspection had to be carried out by the light of nature. Many of the delay action fuzes were operated by clockwork and stethoscopes were used to hear if they were still ticking, or if the disturbances caused by the work started them in action again.

"Such primitive methods could not be allowed to continue to be used indefinitely and, by the personal intervention of the Prime Minister, the aid of scientific and civil engineering organizations was called in to investigate and follow the development of enemy devices, to produce methods and implements for the sterilization of fuzes, and to develop means and tools for their extraction and for the more rapid and simple methods of excavation of the bombs themselves. For sterilization, various methods of gumming up or 'freezing' the mechanism of the fuzes were gradually produced and brought into use. For digging out the bombs better methods of revetting the sides of the excavation were introduced.

"With all these aids the work of the bomb disposal personnel became easier and considerably safer, though it was still to remain an extremely dangerous job, and one that demanded a very high standard of courage and devotion to duty on the part of officers and other ranks. But the greatest admiration must be extended to those members of the service who, in its early stages with little knowledge of the problem, with inadequate equipment and a very elementary organization, carried on cheerfully, and who suffered a high percentage of casualties. These small parties were called on at short notice to deal with bombs neither the nature of which nor the method of operation of their fuzes was known. Lying frequently in soft soil at considerable depth the RE parties had to dig down to them, never knowing when they might explode, timbering the sides of the excavation largely by the light of nature, and with inadequate tools. Then having uncovered the bomb it had to be decided in regard to local circumstances, whether it should be destroyed where it was, removed complete to a place where it could be destroyed with impunity, or whether the fuze, possibly of unknown performance, should first be extracted. Whichever of the two latter methods were employed, there was always the danger that tampering with the fuze, or moving the bomb, would set off the fuze or restart the delay action mechanism. It is not surprising that such cold-blooded heroism, displayed under the eyes of the population, should have captured the admiration and affection of the public."

To all intents and purposes Bomb Disposal in the RAF started in July 1939, when a member of the instructional staff at the RAF Empire Air Armament School, RAF, Manby, Lincolnshire, was given a lot of bits and pieces, told that these were parts of a German aircraft bomb fuze and asked to see if they could be made to work. The project was to be dealt with as "secret" and in the interest of security the team working on this task was to be limited to two people. An NCO of the Station Signals Staff was co-opted to assist on the electrical aspects and these two spent several hours in their spare time piecing together the totally unidentified bits. Unidentified that is, from the point that there was no indication as to which part fitted where or even if a part actually belonged to the whole. Eventually the job was done, by substituting an ordinary flash lamp bulb for the electric igniters, an effective demonstration could be given showing the electrical charging of the fuze and the firing of the igniter when the fuze was exposed to shock such as the shock of impact.

Line drawings and diagrams of the break down of this fuze were made and the method of operation was described in a paper that was produced by the team for the School. At the same time, as it had been appreciated that under certain conditions fuzes of this type would necessarily fail to function on impact of the bomb with the ground, but that the fuze could

subsequently become "live", a method of rendering such a fuze "safe" by "extracting the electric charge" was evolved and a prototype "discharger" was produced.

In the August/September of 1939 this information and an original design of a fuze discharger, together with the re-built fuze, was passed directly by the RAF Empire Armament School to the Ministry of Home Security. Hence a certain amount of information was available but it never reached those who were called upon to deal with unexploded enemy bombs.

At about this time, the Air Ministry, considering that attacks would undoubtedly be made on our airfields, decided to establish "demolition parties" on certain key airfields. The general idea at that time was that where any difficulty was likely to be experienced in getting rid of an unexploded missile, the missile was to be surrounded by sandbags to prevent any unnecessary damage to near-by buildings, etc, and was to be demolished where it lay. The Works Flights would fill in the craters so formed and the airfield made operational in the shortest possible time (in those days the airfields were grassed, concrete runways did not come into general use until later).

In June 1940, the RAF Empire Armament School started a series of one week courses in dealing with unexploded bombs. Four days were devoted to British and two days to German bombs. RN and RE Officers also attended these courses so it was in fact the first Joint Services School of bomb disposal. The numbers attending grew so much that the RAF set up a school at Melksham and, in August 1940, the Navy set up their own school. The naval bomb school eventually moved to HMS *Volcano* in Cumberland.

The Army followed suit by setting up a bomb disposal school at Donnington in September 1941, with a BD Officer in each Command to teach reconnaissance.

It was shortly after this that two civil organizations were formed which greatly assisted the work of the bomb disposers. The first was the selection of certain members of the ARP and police for training as bomb reconnaissance officers. Their job was to investigate reports in local districts and discredit if necessary. In this way many valuable hours of bomb disposal officers' time was saved.

The second was the formation of the auxiliary bomb disposal service formed from volunteers in factories and large works. RE instructors gave them a short course followed by a test. It was their job to deal with unexploded bombs in the immediate vicinity of their factories so that work would be held up for the minimum period. These auxiliaries varied a lot but the best were quite superb and disposed of bombs in neighbouring as well as their own factories. They were eventually absorbed into the Home Guard but retained their BD identity.

The growing number of unexploded bombs were causing great concern because of the disruption caused in industry and the large number of people evacuated from their houses. The total number of UXBs is not accurately known but in one week in late 1940, no less than 900 high explosive bombs were disposed of. In spite of this activity there were, at times, as many as 1,000 known UXBs in London alone, and nearly three times that number in the whole country.

Bomb disposers were at a premium and, in order that they should not be delayed when entering an area, which had been evacuated due to the

presence of a UXB, a special BD badge was worn on the left sleeve of the battle dress. All Service BD trucks had their mudguards painted red and a blue filter fitted to the near side head lamp. (Royalty had both side lights fitted with a blue filter). These distinctions were highly prized at the time and today they are cherished by everyone posted to an Army bomb disposal unit.

With the commencement of the blitz on London in the autumn of 1940, followed later by blitzes on other major cities such as Coventry, Birmingham, Liverpool and Glasgow, naval mine disposal officers were required to deal with "Land Mines". These land mines were in fact mainly long cylindrical German sea mines used as blast bombs and often dropped by parachute. To the bomb disposer they were a particular menace because some fuzes incorporated a photo-electric cell, which would cause detonation when subjected to a single candlepower of light. The object of this photo-electric cell was to protect the magnetic, acoustic and hydrostatic influence units housed inside the mine. A further hazard was a fuse sensitive to water. The moisture in a man's breath was sufficient to operate the fuze. It was, therefore, necessary to work in silence, in complete darkness, wearing a surgeon type mask and using non-magnetic tools during immunization.

Some of the drama, frustrations and uncertainties of the time is captured in the following account<sup>6</sup> of a naval disposal party sent out on a job in 1940.

"For events soon showed that the Germans were prepared to go a long way to prevent us discovering the secrets of their mines. They got ready two special mines with apparently the sole object of killing some of our experts and frightening the remainder from ever trying to strip a mine again. Soon after midnight on the 16th August enemy aircraft laid one such mine a few miles behind Portsmouth and another a few miles behind Portland.

"The mine behind Portsmouth fell near Bere Farm at North Boarhunt and was dropped by a solitary, circling aircraft. There was a noisy explosion but little or no shock. Commander (M) went out next morning to find Bere Farm. Eventually a village grocer's boy said 'Oh, it's the parachute mine you are looking for, is it, sir? Why, that be just down the next lane'.

"The mine was in pieces but the main charge had not exploded and the main primer and detonator were still intact. No bomb fuze, clock or magnetic unit were fitted, and there had obviously been an electric booby trap, which for some reason had been sprung when the mine hit the ground. It looked as though the booby trap was designed to detonate the main charge but had failed to do more than explode a small auxiliary charge. All the evidence went to show that the mine had been 'planted' with the object of destroying the people who tried to investigate it.

"The similar mine behind Portland was at Piddlehinton and was undamaged. By the time this was tackled the equipment was available and the instrument for cutting the shell had been completed in three days, and nights, by the National Physical Laboratory. Here the evidence of 'planting' was even clearer than at Boarhunt. The mine was found lying on the slope of a grass field about ten miles north of Weymouth. The nearest military objective was over two miles away. The night was fine with a full moon and there was little or no mist. The aircraft that dropped the mine seems to have approached fairly high from the south, dropped the mine almost immediately, and then returned over Weymouth.

"When Vernon's party arrived, the mine was safe in the custody of

Constable Fish, the local arm of the law, and was guarded by some soldiers who kept at a very respectful distance. The main detonator and primer were removed, in case they were connected to a clock device, and proved to be normal.

"Examination showed an astonishing box of tricks. They were studied with great interest, and it was decided to cut a hole above the battery so that the leads going away to the auxiliary charge could be cut. At first the cutter did not work very well and the compressed air ran out, but at last the shell was penetrated. At this stage, when everyone was keyed up, first one, then another, then they all smelt burning. 'Pitch' said one. 'It's getting worse' said another. They were just preparing to run when Commander (M) found a cloud of smoke coming from his jacket pocket. He had done the usual silly thing with a pipe.

"Real excitement was to come, however. After cutting the leads coming away from the battery, there was still a very complicated mechanically-fired charge in the rear compartment. The compressed air had run out again, the cutter was misbehaving, and it was getting late. They had already been five days on the job. The word was given to use plastic explosive to make a hole in the rear door. All took cover in a near-by field until the plastic explosive was detonated, and Commander (M)'s binoculars showed that a neat hole had been cut. As the party advanced excitedly to see the result, there was a loud explosion and everyone fell flat on his face. Luckily, no one was hurt, although nasty bits of metal were scattered amongst and beyond them. A lorry a hundred yards away was hit by the parachute shackle. The mine was in flames and there were bits of blazing explosive all round. The exact details of the mine were thus never known, nor the reason for the second explosion.

"The mining department had little time to worry about booby trap mines. The Battle of Britain was in full swing, so was the enemy mining campaign. One emergency after another was met with enthusiasm and skill, and there was never a dull moment."

An indication of the conditions of work, and the type of courage so often called for, is shown in the official citation when the George Cross was awarded to Major C. J. Martin RE on 11 March 1943.

"During the night attack on London on 17th/18th January, 1943, a large calibre bomb fell in the warehouse of the Victoria Haulage Company at Battersea, and, after tearing its way through roof girders, machines and packing cases, came to rest unexploded immediately beneath the bed plate of a very large lathe.

"Owing to the fact that the warehouse was full of new and heavy machine tools from the USA, the Ministry of Supply applied to the Regional Commission for Category A1 (i.e. highest priority, involving the immediate removal in spite of risk). This was granted and on the morning of 18th January, 1943, a working party commenced disposal operations.

"During the day, 18th January, another category A1 bomb had been found to contain an entirely new type of fuse which, on examination, during the night of 18th/19th January, was found to embody characteristics which indicated it to be not only more formidable as an anti-handling and booby trap than any other type so far met, but to be proof against any known technique equipment. On the same night the bomb at Battersea was identified as a 500 Kilogramme (2 ton) projectile with two fuses and the casing so

distorted as to render their withdrawal impossible. On further examination one of the fuses was found to be of the new type. This necessitated the closing down of the large flour mill (flour was strictly rationed on account of shortage of supply) next door to the Victoria Haulage Company owing to the excessive vibration, and work on the bomb was temporarily suspended.

"In view of the necessity of getting the flour mill working again and for removing the threat to machinery of the utmost importance to the war effort, it was decided to attempt to remove the base plate of the bomb and extract the main explosive filling. Major Martin, who was fully aware of the extremely formidable characteristics of the new fuse, undertook the task and assisted by Lieutenant Deans, on 20th January, succeeded in removing the base plate only to find that the bomb contained solid cast TNT, which could only be removed by the application of high temperature steam. It was considered that the risk of detonating the bomb would be too great if the normal steaming out process was used by remote control owing to the very high temperature generated and the excessive force of the steam jet, the effect of which on a possibly loosened fuze pocket could not be foreseen. It was decided, therefore, that the only way was to apply the steam nozzle by hand, and only long enough at a time to soften the TNT sufficiently to allow it to be scooped away in small quantities. This not only entailed further evacuation to make working space and supporting the bomb in such a way that it could not slip or be moved, but also involved two men being constantly in the bomb pit to manipulate the steam and cooling pipe and to scrape away softened explosive. This extremely arduous task was undertaken by Major Martin who, assisted by Lieutenant Deans, worked continuously from the afternoon of Wednesday 20th January, through the night until 8.30 am on 21st January, by which time they had succeeded in removing the entire main filling of cast TNT from the bomb. The work carried out in a cramped hole filled with steam and water in which they had to lie alongside the bomb for nearly twenty-four hours during which time both officers had every reason to believe they were in extreme danger. Throughout the long and hazardous operation Major Martin displayed cold-blooded courage and tenacity of purpose with complete disregard for the appalling risks involved."

Major Cyril Martin was later appointed Chief Instructor of the Army Bomb Disposal School. Standard or pressure diving was taught at the school and also the rendering safe of anti ship mines. The instruction included Combined Operations Sapper Officers, also a Chief Petty Officer and Petty Officer RN. Frogmen were trained at the Combined Operations Experimental Establishment.

For the first time in a full scale invasion, the planners of "Overload" decided to include a BD element in the early stages of the landing. During the landings attacking troops were hampered by underwater obstacles. Clearance was a Naval responsibility undertaken by Landing craft Obstacle Clearance Units (LOCUs) consisting of one officer and ten ratings. However, beach group CsRE felt a definite need to have divers readily available under their command.

This resulted in the formation in October 1944 of BD Platoons (Light) RE. Each platoon consisted of two officers and thirty men and operated as two LOCUs and a headquarters. All men were specially selected and attended intensive courses. They were trained as pressure divers and frogmen and

received instruction in rendering safe anti ship mines. Five of these platoons went to India in preparation for the invasion of Burma and Malaya.

The story of the abortive attempt by German frogmen to demolish the Nijmegen bridge after its capture is generally known. One of the charges went off blowing a hole in the decking and a second only partially exploded. The Naval Clearance team in the area was commanded by the fabulous Lieutenant Bridge, Royal Australian Navy, who was awarded the George Cross and no less than three George Medals.

He well knew that other charges must have been fixed underwater and that their delay fuzes would be due to operate at any minute. Although it was a very cold day, he immediately took off his jacket and plunged into the icy water without his diving suit. He found a large cylindrical mine and, having attached cordage to it, proceeded to haul it up the bank. His admiring audience were still at a respectful distance when he immunized it and drove off in a lorry.

A BD subaltern, who was in the area, continues the story.

"We were worried that the Germans might try it again. When an infantry patrol reported a small dump of what were evidently the same type of mine, up river in the no-man's land beyond the Nijmegen bridge-head area, I was sent to investigate. Thus I was able to take a BD patrol into ground normally frequented only by infantry patrols. Whatever we did, we were to do it without attracting enemy attention. We found the mines and found how the flotation chambers operated. We flooded them, safely moored, in five feet of water. Only a crane could move them now and they would require new flotation chambers attached to either end.

"Although we did little underwater disposal work, we were frequently in demand for underwater work at wet bridging sites, clearing booby trapped houses in Brussels and blowing open safes in Germany so that intelligence branches could examine their contents."

It is not generally known that of the hundreds of thousands of high explosive bombs dropped on this country and on the mainland of Europe, by both sides during the Second World War, one in seven failed to explode. The reason was safety insurance. A bomb must be absolutely safe in store, when handled and in transit by road or air. Further it must be safe after release until the aircraft is out of the danger area. All these, and many other factors designed to prevent it going off prematurely, account for the enormous number of unexploded bombs which had to be made safe. In contrast comparatively few Japanese bombs failed to explode. This was due to their disregard of safety measures and their contempt of human life. As a result it was not uncommon for Japanese bombs to explode in factories or aircraft long before they reached their target.

The procedure for disposing of buried bombs is as follows: The initial reconnaissance will reveal whether the incident reported was caused by an unexploded bomb. The majority of incidents reported as bombs are discredited as collapsed drains, jettisoned aircraft petrol tanks, fishing floats, buried cats, pest holes and a variety of things which are reported every time there is a bomb scare.

If the incident is not discredited the next stage is to decide on the location in plan and to estimate the depth. Special bomb locators are required for this task but, as with mine locators, they are unable to differentiate between bombs and other metal objects. Once the position is known a shaft is sited,



the earth excavated and timber frames positioned to form a revetment.

When the bomb is reached the fuze must be identified. Where markings on the fuze indicate the type, immunization follows. Where the type is not known to the bomb disposal officer he must be in a position to take a radiograph of the fuze using a radioactive isotope, process it and interpret the principle of operation. Needless to say, interpretation requires great skill and considerable knowledge of fuzes.

Once the fuze is identified, immunization follows if this is possible. Next, provided no anti-withdrawal device is suspected, the fuze is removed. The bomb can now be taken away to a bomb cemetery for demolition or the explosive removed on the site. Finally, to complete the job the timber revetment is removed and the shaft backfilled.

Without going into the technicalities of equipment used, a brief statement of the principles governing the immunization of certain types of fuzes used in the last war, will show how the problem was tackled.

Usually electrically operated fuzes are charged from a power supply in the aircraft as they leave it. The electricity is stored in a reservoir condenser and gradually leaks through a high resistance to a firing condenser, after which, and usually as a result of impact of the bomb with the target, the electric current heats up an ignitor bridge and initiates the explosive.

Initially the fuze was rendered safe by depressing the fuze plungers, which caused a short circuit and discharged the condensers. When the Germans discovered our method they incorporated a secondary circuit which fired when the fuze plungers were depressed. Subsequently it became necessary to render fuzes safe by the injection of a liquid of predetermined conductivity, which discharged the condenser. The conductivity of this liquid is all important because, if it is too strong, it will cause a short circuit and fire the charge, if it is too weak it will not discharge the condenser, leaving the fuze live.

Before a battery operated fuze could be rendered safe the battery had to be frozen to make it inert and it had to be kept frozen until the fuze was removed. Either liquid oxygen or a mixture of carbon dioxide and methylated spirits were used as freezing agents.

Mechanically operated fuzes function on the action of a striker hitting a percussion cap. When the bomb strikes a target the movement of the striker is effected by springs, inertia or the force of impact. The fuze is rendered safe by the introduction of a liquid (similar to dental cement) which rapidly solidifies inside the mechanism and jams everything solid thus preventing the striker moving on to the cap.

Clockwork operated fuzes are armed either electrically or mechanically, the action of the striker is governed by the clockwork mechanism. The object is to delay the explosion of the bomb for a certain period so that the maximum disruption is caused to the enemy by uncertainty and fear. Rendering safe is done in two stages. First the clock is temporarily stopped by applying a large electro magnet which holds the balance wheel in a fixed position. Then a solution is injected which clogs up the escapement mechanism so that the clock will not restart. The solution contains a gritty solute which remains in the clockwork even if the solvent evaporates. During the early part of the war sugar was used for this solute, but bomb disposers were quick to discover that salt was equally effective and they used the sugar for tea on the site. When the authorities discovered what was going on they issued

salt, but continued to mark the containers "BD Sugar". The indignation at subsequent brews up can be imagined.

Fuzes were by no means straightforward. Some contained a mechanism which would go off if the bomb was moved or subject to vibration. Even a tap with a pencil would be sufficient for a sensitive fuze to operate. There were booby traps which caused an explosion if any attempt was made to withdraw a long delay fuze and there were combinations of the above.

By 1941 bomb disposal was a highly organized and efficient organization. Research into new techniques and improved equipment, under the direction of the Unexploded Bomb Committee, was proceeding as the demand arose to combat more complicated enemy fuzes. In this respect radiography played an important part. By taking a radiograph of a new fuze it was possible to tell how it worked without moving it.

Bomb disposers are probably more security conscious than many branches of the services because the result of a security leak is likely to affect them directly as individuals. If the enemy learn that we have developed a new method of improving the rate of fire of a gun, the result of the leakage is unlikely to be brought home directly to the individual. On the other hand, if the enemy hear of a new technique for neutralizing bomb fuzes, they will redesign the fuze so that it operates when this new technique is adopted. In this way many bitter lessons were learnt.

After the war, the Army School of Bomb Disposal, which had been an integral part of the SME at Ripon and Chatham, eventually moved to Horsham. Ever since the end of the war all Naval Torpedo Officers, appointed to bomb and mine disposal jobs, have attended courses at the Army School.

On 1 January 1959 the RAF and Army BD Schools amalgamated to form The Joint Services Bomb Disposal School. It is probably the smallest Joint Services School in existence. The combined services instructional staff is thoroughly integrated and the Chief Instructor, at present a Sapper Major, will be followed by a Squadron Leader. Royal Naval instructors are available from the clearance diving branch at HMS *Vernon*.

The school is administered by HQ Bomb Disposal Unit (UK) RE and receives technical direction from the Joint Services Bomb Disposal Methods Committee, on which each service and certain ministerial establishments are represented.

The school has three main functions. It is responsible for running bomb disposal courses to meet the current operational needs of the three services. The Army's operational requirement was described by Major Hartley in this journal published in December 1959. The Royal Navy have an operational team in each Naval Command and the RAF have BD Flights part of whose job is the clearance of bombing ranges and field training areas including the site of the early warning system at Fyling Dales Moor in Yorkshire.

With the future problem relatively unknown, teaching is confined to principles and these are demonstrated and practised using current equipment and when obtainable, current missiles. In addition the school can run short bomb reconnaissance courses for police and civil defence as required.

During the summer the school is responsible for training AER and TA bomb disposal units. This makes a welcome break from the routine of courses particularly since reserve army training embraces many Sapper and civil subjects outside bomb disposal. Taken as a whole this work is most rewarding.

The third function of the school is research and development to discover new methods of tackling new problems. The need for security prevents me from describing current problems and how they are being tackled. It is a pity because the work is fascinating and developing along traditional lines. To us it can also be frustrating because we bump up against other security barriers. The formation of this school has cut out inter-Service rivalries and jealousies, but it has not given us access to all the information we need. In bomb and missile disposal, when lives are at stake, it is criminal for individuals to be confronted with explosive items of which they know nothing, because responsibility lies with a scientist, who has specialist knowledge, and who is not readily available. This situation calls for knowledge, not trial and error.

If this article has any value I hope it will help to achieve two things. Firstly to establish that we really do "Need to Know" and must be given access to classified information if we are to do our job properly. Secondly to show that bomb disposal, as with so many other things, should really be an integrated joint service concern, possibly on the lines of the United States Explosives Ordnance Disposal. Even in the Army there is an illogical delineation of responsibility, between the RE and RAOC, for the disposal of explosive items.

#### REFERENCES

- <sup>1</sup> "Floating Obstructions and Submarine Explosive Machines" by General Sir John (later Field Marshal Lord) Fox Burgoyne, GCB, Inspector-General of Engineers 20 July 1863.
- <sup>2</sup> Mines, Minelayers and Minelaying by Captain J. S. Cowie, CBE, RN.
- <sup>3</sup> History of Submarine Mining by Lt.-Col. W. Baker Brown, RE.
- <sup>4</sup> H. J. Gough Esq., CB, MBE, DSc, MIMechE, FRS, Chairman of the UXB Committee when presenting the 1947 Thomas Hawksley Lecture to the Institution of Mechanical Engineers.
- <sup>5</sup> The history of the Corps of Royal Engineers Vol. VIII Chapter V by Major-General R. P. Pakenham-Walsh, CB, MC.
- <sup>6</sup> A short history of HMS Vernon 1930-55 by Commander E. D. Webb, RN.
- <sup>7</sup> *London Gazette*.

#### ACKNOWLEDGMENT

I would also like to thank those officers in all three Services who have checked this article for accuracy and made many helpful suggestions. In particular I would like to thank Major A. B. Hartley, MBE, GM, RE, for permitting me to take references from his book *Unexploded Bomb* (Cassells).

# The RE Band

By CAPTAIN K. V. STEWART, RE (SECRETARY, RE BAND)

WITHIN any RE unit, whether of the Regular or Reserve Army, there are probably a number of occasions every year when it is felt that the RE Band, or an element of it, should be present in support of the unit. Frequently the full band is required for an important ceremonial parade, a recruiting drive, or some function which is likely to attract wide public interest. At other times it may be that only a small orchestra or dance band is wanted. If you have ever tried to obtain the Band for such an occasion you may have been a little irritated to learn that it was already booked to play at some seaside resort for a fortnight; or you may have been told that you would have to pay fifteen guineas for a dance quartet. What is the good of a Corps Band, you ask, if it spends its time playing for civilian organizations and asking high fees for playing at military functions?

In this article an attempt is made to answer such questions as these by explaining briefly what the Band is and how it is administered, so that you may have a better understanding of what it can and cannot do.

## BRIEF HISTORY<sup>1</sup>

In 1856, a Regimental Brass and Reed Band was established at the Depot of the Royal Sappers and Miners, which had just moved from Woolwich to Chatham accompanied by their Brass Band, which had been formed solely for Depot purposes. By 1871 there were thirty-four musicians in the band which was led by the Bandmaster, Herr Sawerthal, a native of Bohemia. In 1919 this appointment was raised to the status of Director of Music, and Captain Neville Flux, who had been Bandmaster since 1905, received his commission; he continued to serve at Chatham until five years after his promotion to Captain, by which time he had completed over twenty-seven years in command of the band. During the earlier part of the First World War, while continuing to perform their normal duties, members of the band were also employed either as NCOs or as drill instructors to assist training the large numbers of recruits received at Chatham. They toured France from December 1916 to March 1917, chiefly in the forward areas, but in the summer of 1918 many musicians were selected for training as normal reinforcements. By the time of the Armistice temporary replacements had been found for thirteen of them, but these men were soon demobilised and the original members of the Band returned to Chatham. During the last war the band remained intact and in May 1944 they went on their first overseas tour since 1919: this tour included a visit to Palestine, Syria, Jordan and Egypt and lasted until January 1945.<sup>2</sup> It continued to remain a purely Corps organization until 1948 when it became an established unit of the Army, supported mainly from public funds. The orchestra, however, continued to be maintained by subscriptions from the Officers of the Corps.

In 1949 approval was given for the formation of a Minor Staff Band which

*Notes.* At the end of this article there are notes on matters of detail which may be of interest to readers, particularly those concerned in organizing functions at which the Band is required to play.

became known as "The Band of the Corps of Royal Engineers at Aldershot".<sup>3</sup> This was not the first time there had been an Aldershot Band: at the end of the last century a "voluntary" band had been formed at Aldershot and from 1911 until its dissolution in 1931 regular grants from the Chatham Band Fund had been made to support this band. Major L. N. Dunn was the first Director of Music of the new Aldershot Band and he held that appointment until 1958 when he was succeeded by Lieutenant (now Captain) Francis E. Hays. The Aldershot Band has already toured extensively and has visited BAOR and Cyprus; when in Cyprus in 1959 the orchestra gave a memorable concert in the ancient amphitheatre at Curium—this is believed to be the first occasion on which "live" entertainment has been given there for over a thousand years.

Since the war, the Chatham Band has visited BAOR on five occasions and it toured in the Middle East in the autumn of 1951; it has also undertaken a large number of engagements in the UK which have increased in variety and number every year, and have included several performances in Buckingham Palace.

After fourteen years' service with the Chatham Band, Major A. Young retired in 1958 and was succeeded by Major B. H. Brown, MBE; it was after only three years that he was posted to Kneller Hall and promoted into the appointment of Chief Instructor and Advisor to the Inspector of Army Bands. While in this appointment he will continue to wear his RE cap badge, so with Major W. G. Lemon, his successor at Chatham, there will now be three Directors of Music shown in the Corps List.

#### ORGANIZATION

Both bands are similarly organized, though the authorized strength<sup>4</sup> of the Chatham Band includes sixty-six musicians compared with forty in the Aldershot Band. These figures include the junior musicians all of whom are trained in the RE Junior Musicians School at Chatham. It is seldom practicable for either band to parade at full strength as a small number of musicians will normally be attending courses at Kneller Hall and it is not always desirable to fill all the vacancies for junior musicians.

It is not always appreciated that musicians are frequently recruited from line bands (ie those of RAC and Infantry Regiments) as well as from civil life. While this might at first sight appear to be a strange practice it is accepted because owing to the nature of their duties, musicians in line bands are restricted in their opportunities to further their musical training; whereas musicians in a staff band are based in the UK and are constantly encouraged to improve their musical ability.

By definition<sup>5</sup> each of the military bands includes wood-wind, brass and percussion instruments, but neither has an authorized Corps of Drums which can be used for "Beating Retreat". However, as such a body lends so much colour and effect at this ceremony, the Chatham Band have maintained their Corps of Drums for this purpose and they do, of course, provide a considerable additional attraction when the band is playing at any public function. Unfortunately the Aldershot Band does not have sufficient players to do this and they cannot, therefore, compete in terms of spectacle against the Infantry of the Line bands, all of whom have a separate Corps of Drums established within the regiment. Nevertheless they can give an effective marching display.

Each orchestra<sup>6</sup> is made up from members of the military band but the

finances of the orchestras are completely separate from those of the military bands. Similarly the dance bands are completely separate entities within the bands and they are financed from paid engagements only. Both the orchestras and the dance bands are unofficial combinations and the musicians playing in them do so voluntarily and receive additional pay for each engagement they undertake.

The control of the Bands is vested in the Engineer-in-Chief, though he delegates certain of his powers to the RE Band Committee<sup>7</sup> and to the Commandant SME and the Commander Training Brigade RE. Matters of administration and discipline are within the province of the holders of these two appointments, while the Band Committee is responsible for co-ordinating the programmes of engagements, exercising financial control and advising the E-in-C on matters of policy.

#### DUTIES OF THE BAND

The most obvious duty of the Military Band is clearly to take part in ceremonial parades in which units of the Corps are involved. Such parades include those attended by units of the Reserve Army though other duties will often have to take priority over a demand for the band on such a parade: the Military Bands *do not normally play on parade below full strength.*<sup>8</sup>

The orchestras cannot perform satisfactorily out of doors unless a loud-speaker system is provided. It is customary, therefore, for an element of the Military Band to play at open air functions where entertainment is required for Officers of the Corps, and their guests—such functions include the Colonel Commandant's "At Home" at Hurlingham and playing at Lords on the occasion of the annual RE *v* RA cricket match. It is also obligatory for the Military Band to obtain engagements to bring the Army to the favourable notice of the public. This is most frequently achieved when the band participates in military tattoos and at displays specifically aimed at attracting recruits. The Military Band Fund derives no income from any of these duties, although the expenses of the band have to be paid from non-public funds when they travel to Hurlingham and Lords, or elsewhere for similar domestic engagements.

To help meet the expenses of running a military band it is most desirable that engagements are undertaken for which a fee is received. Often such engagements will also bring the Army into the public eye and, although on occasions they may only be heard by a very limited audience, the listeners are usually very discriminating. Typical of the engagements which are regularly accepted are performances for the BBC, in the Royal Parks, and with public corporations, particularly those at seaside resorts, under contracts covering periods of one week or more. It will be appreciated that most of these engagements are only undertaken during the summer months and it is necessary to negotiate and draw up contracts many months in advance. Furthermore, as it is not easy to obtain good engagements of this type, once such a contract has been obtained in one season, every effort is made to repeat it in subsequent years.

It must not be thought that finance alone is the reason why the band has to obtain fee-earning engagements. The Corps as a whole gains by the eminence of its bands in the outside world of music and it is, therefore, important for them to achieve such eminence. This can only be done if the musicians in the band are of a high calibre and if they are keen to improve

their ability by spare time practice. For a musician to achieve a good name as a soloist his band must be in the limelight and he must be frequently applauded for his efforts. This in itself will attract the right men into the band to replace those who retire and will, incidentally, lead to the band giving greater pleasure and benefit to members of the Corps. It is indeed a vicious circle, but once a band can command attractive tours, and still provide the desired inducements to its musicians, it will have achieved such eminence as to enhance the name of the Corps. Once such a status is achieved it has to be maintained; public engagements must continue and adequate time must be set aside for practice.

It will be appreciated, therefore, that it is for the Band Committee to satisfy the conflicting demands of units, so far as they can, while keeping the band on a sound financial footing and above all ensuring that the name of the Corps as a whole is gaining the maximum benefit from the engagements accepted by its bands. Inevitably these considerations have to be taken into account at the November meeting of the Band Committee when the bands' programmes are drawn up for the coming year, and this is one reason why bids from units and commands are required so far in advance.<sup>9</sup>

#### FINANCIAL ASPECTS

It is desirable for the bands to undertake fee-earning engagements from which the sum total of the profits earned by the two bands are of the order of £1,800 every year. These profits are shared between public funds, the Band Fund, and the members of the band. The income to Band Funds is derived from two other sources: a specified sum is received as a basic grant from public funds,<sup>10</sup> and to this is added an "additional grant" which decreases as the profits from private engagements increase. To offset this decrease in the additional grant, the Band Fund receives 20 per cent of the first £1,000 net profits, and 5 per cent of any further profits. The net income to bands is, therefore, very small in relation to the apparent value of the contracts which they may accept.

The annual expenditure incurred by the two Military Band Funds totals about £1,400 and arises from the payment of fees for performing rights and tuition of the musicians, administrative expenses to cover insurance and musical scores and lastly, but by no means least, the cost of upkeep and replacement of the instruments. Maintenance costs are not infrequently increased as the result of adverse weather: heavy rain on a ceremonial parade may result in a set of new drum skins being required at considerable cost.

#### THE ORCHESTRAS

It has already been stated that the orchestras are maintained by subscriptions from the Officers of the Corps. For many years officers each made their own individual subscription to the orchestra, and many subscriptions were also received from retired officers. As there were a large number of non-subscribers, who were benefiting at the expense of their brother officers, it was decided in 1958 that officers should be asked to discontinue their subscriptions and a grant would be made from the RE HQ Mess Funds towards the cost of maintaining the orchestras; this grant was also designed to provide orchestral pay for all the members of the band who play in Regular RE Officers' Messes on guest nights, or when an orchestral concert is given in the RE HQ Mess.

The orchestral expenses are similar to those incurred by the Military Band and although there is a substantial income received from investments held, it is still necessary for orchestral engagements to be obtained to balance the expenditure from the *Orchestral Funds*.<sup>11</sup> To this end contracts are arranged with public corporations which have bandstands suitably equipped for use by the orchestra. Engagements are also undertaken at chartered and livery company dinners. Whenever an engagement is undertaken by either the Military Band, the Orchestra or a Dance Band it is necessary to ensure that the fee charged is not lower than that laid down by the Musicians' Union for a similar number of civilian musicians. In the case of entertainment provided for regular Sapper officers,<sup>12</sup> all of whom support the orchestra, this is not of course applicable. When, however, the orchestra, or a section of it, plays for instance at a TA function, then the fee charged is liable to be somewhat larger than might be expected.

The size of each orchestra is variable and is adjusted according to the type of performance that is required and any physical or financial limitations that may be imposed. The Chatham Orchestra at full strength numbers forty instrumentalists and it does not play as an orchestra with fewer than twenty-one.<sup>13</sup> Musicians in the orchestra normally wear No 1 dress and although a small number of suits of the pre-war full dress are still in the possession of the band these are not authorized to be worn on normal duty.

#### DANCE BANDS

A dance band of variable size can be provided from either Chatham or Aldershot. These bands are maintained solely from the charges<sup>14</sup> made for the performances they give, and the unit or organization employing them is responsible for paying all their expenses and a fee, which is designed to cover dance band pay and to contribute to the cost of provision and maintenance of instruments, equipment and music. A special form of dress has been authorized for wear by dance bands but this has not yet been purchased: No 1 dress is normally worn, though on special occasions, pre-war full dress is permitted.

#### TRAVEL EXPENSES

It is not generally appreciated that the travelling expenses of the band are not chargeable to Normal Travel Votes except when they are undertaking certain specified duties, such as performing at ceremonies when a member of the Royal Family is representing the Sovereign, or when a RE unit is embarking on, or disembarking from a ship at a UK port. When the band is participating in recruiting displays sponsored by District or Command Publicity Committees these expenses are met from Command Recruiting Funds. The cost of moving the band to play on parades for annual administrative inspections, "At Home's", guest nights or for the entertainment of all ranks of the Corps is met from a grant allotted annually to the Corps Band. This allotment in itself sets a further limitation on the number of engagements which may be undertaken by the band in any one year.

#### CONCLUSION

In conclusion, it should be mentioned that in future it is proposed that each band should tour BAOR every year for about a month, and this commitment will considerably increase the demand on the services of the band, particularly in the late spring when one of these visits will be made. Any unit



which is likely to want a band for any function should, therefore, plan well ahead and as soon as reasonably firm dates are known the Band Secretary should be informed. If the Aldershot Band is likely to be required, then the Band Secretary at Aldershot (DAA & QMG, Training Brigade RE) should be told at the same time.

## NOTES

1. A detailed history (in typescript) of the RE Band is held in the Corps Library.
2. A more detailed article on the 1944-5 tour made by the RE Band appeared in the July 1945 edition of *The Sapper*.
3. The correct title of the Chatham Band is "The Band of the Corps of Royal Engineers."
4. The establishment of the two bands allow for:—

Rank or Appointment	Chatham	Aldershot
Director of Music	1	1
Band Sergeant (may receive time promotion to WO II after 8 years)	1	1
Sergeants	4	2
Corporals	5	4
Lance Corporals	7	4
Musicians	37	19
Junior Musicians (boys) (one of whom is appointed local Lance Corporal)	12	10

Each band is authorized to appoint a Band Sergeant Major who may be granted the local rank of WO I and WO II in the respective bands; there is also a BQMS (local WO II) appointed in the Chatham Band.

In accordance with Corps Memoranda paragraph 192 the Corporals on the strength of the bands are entitled to be members of WOs' and Sergeants' Messes: this is not always known to members of other messes outside Chatham, and has on occasions caused embarrassment to the NCOs concerned. However, it is at present the Engineer-in-Chief's policy that Band Corporals should be granted the acting rank of Sergeant and there are not, therefore, at the time of writing, any current difficulties.

5. Definition of Military Band given in ACI 54/61.

6. (a) The correct title of the Chatham Orchestra is:—

"The Orchestra (or Light Orchestra) of the Corps of Royal Engineers."

If the Aldershot orchestra is playing the words "at Aldershot" should be added. These titles are only used if the Director of Music conducts. If the number of musicians is less than ten then the combination should be described as an "Octet (or as the case may be) from the Band of the Corps of Royal Engineers" ("at Aldershot" if applicable). A dance band should be similarly described.

- (b) When acknowledgements are to be made they should be as follows:—

For a Military Band—"by permission of the Engineer-in-Chief".

For an Orchestra or Dance Band—"by kind permission of the Officers of the Corps of Royal Engineers".

- (c) If it is desired to publish the name of either Director of Music they should be shown as follows:—

*Chatham*—Major W. G. Lemon, ARCM, psm, RE (appointed 23 April 1961).

*Aldershot*—Lieutenant E. W. Jeanes, LRAM, ARCM, psm, RE (appointed 1 September 1961).

7. The composition of the Band Committee is defined in Corps Memoranda paragraph 165.

8. (a) The parade strengths of the Military Bands are:—

*Chatham*—Director of Music plus fifty-five.

*Aldershot*—Director of Music plus thirty.

- (b) The reduced strengths of the Military Bands vary: the following figures may be taken as a guide for "Bandstand performances".

*Chatham*—Director of Music plus twenty-eight or more.

*Aldershot*—Director of Music plus twenty-five or more.

9. Bids for the band for the coming year are submitted by units through Commands in early November and having considered these bids the Band Committee draws up provisional programmes. By December it is, therefore, possible to accept contracts with public corporations and also to indicate to Commands which unit demands cannot be met because of conflicting bids. Units wishing to apply for the band after November may write direct to the Band Secretary of either Band; if possible this should be done before April when the firm programmes are made for the two bands. After this time it is unlikely that it will be feasible to make either band available to units during the summer months as they will probably have been fully committed.

10. Details of the basic and additional grants are given in Allowance Regulations paragraph 983.

11. Full details of the income and expenditure of the orchestra funds are published every year in the "Reports and Accounts of the Corps Funds".

12. This is in accordance with Queen's Regulations paragraph 1285 (b).

13. The Aldershot orchestra at full strength numbers twenty-five musicians and never plays as an orchestra with fewer than eleven instrumentalists.

14. Dance Band Fees.

(a) For engagements sponsored by a civilian organization, regular military units other than RE, or the TA, the fee will be in accordance with the current union rates and military instructions. The amount of the fee for any particular engagement must be obtained from Directors of Music.

(b) For all engagements with regular RE units the fees are as follows:—

(i) £1 for each musician for any period up to a maximum of four hours before midnight.

(ii) Ten shillings every hour for each musician after midnight or for any hour before midnight in excess of four hours.

---

## A Closed File

By MAJOR T. C. WHITE, RE

IN 1957 at GHQ MELF, while pursuing the unenviable task of sorting out closed files for subsequent destruction, I was surprised to come upon a reconnaissance report dated the 18 November 1885. It was written by Lieutenant C. Godby (later to become Brigadier-General Charles Godby, CB, CMG, DSO) when he was a 22-year-old subaltern in 24 Field Company RE. The company had just moved to Egypt from the Sudan and was busy learning about its new parish just outside Cairo. The report, noticeable today for its good handwriting, was accompanied by an excellent sketch map. Perhaps the most remarkable thing about this report is that it should have survived for so long and that the "closed" file in which it lived had escaped the attentions of the numerous staff officers who must have been its custodians for no less than seventy-two years. Indeed even more remarkable is the tenacity with which it must have clung to the impedimenta of GHQ MELF when that body moved from Egypt to Cyprus in 1955. The report in full reads as follows:—

From Lieut C. Godby RE  
To The Brigadier Major RE  
Sir,

Karra Sut Barracks.  
18th November 1885.

I have the honour to report that I have visited Makattais heights, and have specially noticed the following points:

1. Routes for infantry to Transit of Venus Station.
2. Existing works at Arabis battery & Transit of Venus Station.

1. There are several ways by which infantry can reach Transit of Venus Station without going much by road. The most southerly of three shown on the sketch is practicable for led horses and for infantry in single file. The others are simply places where men could climb up without any great difficulty taking their arms and rations with them. No paths, however, exist at present.

2. There is no work existing at the Transit Station. A very small part of a battery has been begun, but it is not of any great practical importance. The earth and stones could however be utilized.

On the hill behind Arabis battery there is plenty of loose stone, the remains of a building which could be utilized for building a blockhouse. Very little ground however can be seen from this point. Arabis battery consists of an earthwork with embrasures for two guns and a hole put in the rock in rear about 12 feet deep but now half filled up with rubbish.

The south west slope could be swept from a point on the precipice, to the right rear of the battery. From which point also the dead ground in the valley in front of the battery can be seen. There is, however, still a little dead ground about 300-400 yards in front, for men lying down.

I have the Honour to be

Sir,

Your obedient servant,  
Charles Godby, Lieut RE.

#### NOTE ON THE TRANSIT OF VENUS

Observations were carried out at many places throughout the world during the transit of Venus in 1874 in order to calculate among other things the planet's and the sun's distances from the earth. It was a very international affair. According to a Professional Paper, written by Captain W. de W. Abney, RE, in September 1876, British, American, French, German, Dutch, Austrian and Russian official observation parties took part besides many other unofficial parties. Some eighteen months before the actual transit was due to take place the Astronomer Royal started to gather together observers for the official British expeditions and he did his best to obtain the services of as many Gunner and Sapper officers as possible. The official British observations were to be carried out by photographic means and, although the Astronomer Royal was unable to get as many Gunner and Sapper officer observers as he wished, the Corps supplied all the other rank photographic assistants who operated with the official British teams. They were trained in matters of photo-heliograph drill by Lieutenant L. Darwin, RE, at the Photographic School of the SME and this officer also developed a dry plate process, known as the albumenbeer process, that was finally adopted by the British teams and it proved itself to be most effective and trustworthy.

Details of the eleven official British parties were as follows:—

Station	Observers	Photographic Assistants
<i>EGYPT</i>		
Cairo ... ..	Captain Orde Browne, late RA *Mr Newton *Mrs Orde Browne *Miss Newton	Sapper Lafferty and Corporal Mitre Sapper W. Farr
Thebus ... ..	Captain W. de W. Abney, RE *Colonel Campbell *Mrs Campbell Mr Hunter	
Suez ... ..		
<i>SANDWICH ISLANDS</i>		
Honolulu ... ..	Captain Tupman, RMA Lieutenant Ramsden, RN Captain Noble, RMA *Captain Eaton, RN	Sapper M. Meins Sapper G. Currey Sapper W. Myers
Hawaii ... ..	Professor Ferris Mr Barnacle Mr Johnson	
Atooi ... ..	*Rev — Dunn	
<i>RODRIGUEZ</i>		
... ..	Lieutenant Neate, RN Lieutenant Hoggan, RN Mr Burton *Com Wharton, RN	Sapper F. Taylor Sapper T. Currie
<i>NEW ZEALAND</i>		
Burnham ... ..	Major H. S. Palmer, RE Lieutenant L. Darwin, RE	Corporal Shaene and Corporal White Sapper G. Higgins
Naseby ... ..	Lieutenant Crawford, RN	
<i>KERGUELIN</i>		
Royal Sound ... ..	Rev J. Perry Rev — Sidgreaves Mr T. Smith Lieutenant Goodridge, RN	Sapper Hilbert Corporal Wright Lance-Corporal Wilson
Port Palliser ... ..	Lieutenant Corbet, RN Lieutenant Coke, RN	

Those observers with \* before their names were not officially recognized as part of the Expedition.

Other unofficial British observation posts were set up at Karachi, Bombay, Roorkee, Calcutta and Madras, Mount Kenya, Cape Town, Mauritius, and at Adelaide, Melbourne, Eden, Woodford, Bathurst and Sydney. The Americans manned stations at Vladivostok and in New Zealand; the French had observation posts in St Paul's Islands, in New Caledonia, in South Japan and in Pekin; the German observers were stationed in Egypt, Persia, Réunion, the Sandwich Islands and in Shanghai; there was a Dutch station at Batavia; the Austrians had observers in Austria itself and in Japan. The Russians set up a line of observation posts across Siberia to Japan, but owing to bad weather, and the low altitude of the sun, in the majority of cases their observations were unsuccessful.

The transit of Venus across the sun in 1874 certainly produced a great deal of international co-operation with observers of one nation stationed in the sovereign territory of another power. There was unhappily not the same bond of harmony during the recent Geophysical Year.

EDITOR

# Correspondence

## THE QUEEN'S ENGINEERS

There were unfortunately some errors in the article "The Queen's Engineers" that appeared in the June 1961 edition of the *RE Journal*. They were:—

*Boards displayed in the office of the E-in-C.*

The appointment of Director of Fortifications and Works was shown as having existed unchanged from 1904 to 1938. It has been pointed out, however, that this is not strictly accurate. From 1904 to 1927 the Director of Fortifications and Works came under the Master General of the Ordnance, but late in 1927 his Department came under the Quarter-Master-General. The title was then changed to Director of Works and that title persisted until 1935 when, once again, the title reverted to Director of Fortifications and Works.

*RMA Sandhurst Boards*

There were two printing errors. The correct spelling in each case should have been:—

General Sir Wilbraham Lennox, VC, 1830–1897.

Brigadier-General Lord Thomson of Cardington, 1875–1930.

EDITOR.

The Editor,  
*RE Journal*.

27 June 1961.

Dear Sir,

As all Sappers will know one of the most difficult and yet important things in peacetime is to organize interesting and realistic training. With hundreds of Sappers in every form of industry and organization we hope that there are some who can offer facilities for good training. In this way we can possibly help others as well as getting good training and recruiting publicity for the Corps.

Possible ideas are demolitions, small construction tasks or testing security of buildings and establishments, and the more inaccessible and wild the location the better!

There are of course certain limitations on the tasks which can be undertaken but in general anything "legal" can be considered.

It would be appreciated if anyone with suitable ideas would please contact: Officer Commanding, 9 Independent Parachute Squadron, Royal Engineers, Morval Barracks, Cove, Hants. Tel. Farnborough 3100, Ext 39.

I. T. C. WILSON, Major, RE.

Officer Commanding.

BRIGADIER-GENERAL SIR GODFREY D. RHODES, Kt, CB, CBE, DSO, K StJ.  
Box 5077,

The Editor,  
*RE Journal*.

Nairobi, Kenya.

Dear Sir,

*The late Brigadier Sir C. F. Carson, Kt, CBE, MC*

I have read in the September issue of the *Journal* your excellent Memoir on my great friend and fellow Canadian, Bunty Carson, as he was known to us all at the RMC Kingston, in those long-ago days. He was five months my senior in age, but

through the strange circumstances that he decided first of all to take a University Course at Queen's, then changed his mind after a year and came to the RMC instead, he was a year junior to me in the services. But for this fact he would normally have joined the RMC with me in 1907 and one of us would not then have got a RE Commission and one of us would not then have gone to India to the North Western Railway. Luckily for me, his year at Queen's made it possible for both of us to follow our bent. Bunty was an extremely popular leader of his class and we both played in our ice-hockey and rugger teams for the College and I learned to admire him for his many grand qualities. His future wife Doss Brownfield was also known and admired by us all at the College at that time. Bunty's early days on the NWR followed the normal course and while never actually serving alongside him in the Engineering Department, we frequently met. Alas! I failed to get him to play cricket. It was the one game he disliked, otherwise we would often have been together on the cricket field in India.

I lost touch with him again in the first war because while I remained with the Railway Service in France, and elsewhere, he for some reason got directed to field units as you have described. I lost touch again at the end of the war, as he went back to the NWR while I came to the Railways of Kenya.

But in the second war, it was with great satisfaction that I learned that he was to be my DTN at Baghdad with Brigadier Fellowes as his twin, in Movements. Our Movements and TN Organization was a very happy and, I believe, successful one and Fred Carson handled all his problems on the TN side in a masterly way. He worked extremely harmoniously with his opposite number, Fellowes, and later with Andrew Easley who succeeded Fellowes. Fred Carson left us, as you have described, and I saw him only once again. He went back to Canada and I eventually again to Kenya. However we often corresponded and it was a great sorrow to us all when we learned of his first wife's death. Fred was a grand colleague—a great soldier, and a great Canadian, admired and loved by all who knew him; and I can include in this two of his colleagues who are here in Kenya who also worked with him in Baghdad, Andrew Easley and John Collier-Wright, and I know they would like to be associated with me in this tribute. Our sympathies go to his sons, whom I knew, and to his daughter, and to his widow. They will have heard from many other sources the high esteem felt by all who knew him.

Yours faithfully,

(Sgd) G. D. RHODES.

# Memoirs

## BRIGADIER-GENERAL J. R. YOUNG, CB

JULIUS RALF YOUNG was the second son of Major-General Ralf Young, also a Royal Engineer. He was born on 4 October 1864 and educated at Clifton College, where he was a contemporary of Sir Francis Younghusband, and at the Shop. He was commissioned with the Corps on 5 July 1884. After his courses at Chatham he was posted to the Far East where he served both in Singapore and in Hong Kong. On his return to the home establishment in 1891 he spent five years at Chatham where he held successively the posts of Assistant Instructor in Field Fortifications and in command of A (Depot) Company RE.

In January 1897 he was posted to Natal and on the outbreak of the Boer War two years later he was made a Railway Staff Officer. He was one of the beleaguered garrison of Ladysmith and for his services during the siege he was especially mentioned in the despatches of Field Marshal Sir George White, VC.

He was invalided home in November 1900 and after almost a year's sick leave he was employed on works services at Woolwich Arsenal. A further short tour of overseas duty took him to Bermuda where he commanded 27 Fortress Company and, on promotion to Lieut.-Colonel in May 1909, he was posted home to become CRE York Sub-District and later CRE Gosport District with the rank of Colonel.

Shortly after the outbreak of war in 1914 he became an Assistant Director of Fortifications and Works at the War Office, but almost at once he was made Chief Engineer Irish Command with the rank of Brigadier-General. In July 1916 he was posted to Egypt where he became Chief Engineer of No 2 Section of the Suez Canal Defence Zone. The following year he was made Chief Engineer Hong Kong and he held that appointment until he retired in June 1921. He was awarded the CB in that year.

In 1902 he married Ellinor Mary, daughter of Thomas Stoward, Esquire, at St Martins-in-the-Field. They had one daughter. His wife predeceased him in 1940.

Brigadier-General Young died on 9 July 1961 in his ninety-seventh year.

---

## BRIGADIER-GENERAL R. P. T. HAWKSLEY, CMG, DSO, DL, JP

BRIGADIER-GENERAL RANDAL PLUNKETT TAYLOR HAWKSLEY, of Bronllys Castle, Talgarth, Breconshire died on 19 May 1961 in his ninety-first year. He was the son of James Taylor Hawksley, one time of Caldy Island, Pembroke-shire. He was educated at Harrow and the Shop where he won the Sword of Honour. He was commissioned into the Corps on 25 July 1890 and after his Young Officer training at Chatham and a short spell at Sheerness and Pembroke Dock where he was engaged in submarine mining duties, he was posted to India in April 1894. His five year's service there were spent in military works appointments and, in 1897/98, on active service during the Tirah Expedition.

He returned home in 1899 and he was posted to the 1st (Fortress) Company, serving at that time as part of the South Irish Defences at Cork and not at its traditional home Gibraltar. The following year, however, he was sent to South Africa where he was employed for three years in RE Staff appointments, on works service duties and with 47th (Fortress) Company. In August 1903 he was posted home and served for two years with the Ordnance Survey in Edinburgh, Bristol and Cork. He was then for two years Staff Officer to the Chief Engineer Southern Coast Defences at Portsmouth before returning to South Africa in 1910 to become District Officer at Pietermaritzburg and later at Natal.

He was in this latter appointment on the outbreak of the First World War and in October 1914 he was seconded for service with the South African Defence Forces during their successful campaign under General Smuts in German South West Africa 1914/15. In January 1916 he was made CRE 53 (Welsh) Division (TF) at that time engaged in the Senussi Campaign in the Western Desert of Egypt, one of his many tasks was to establish an advanced base at a small and lonely railway station called El Alamein, to become famous a quarter of a century later. The Division then moved to the Sinai to become part of the Egyptian Expeditionary Force. In March 1917 a new Infantry Division, the 74th, was formed from dismounted Yeomanry Regiments and Hawksley became its CRE, but in May of that year he left the Division to become Chief Engineer XXI Corps which appointment he held until the end of the fighting in Palestine when XXI Corps Headquarters was disbanded. He remained, however, as Chief Engineer North Force with headquarters at Bir Salem until being posted home in 1920 after ten years continuous overseas service. For his war services he was awarded the CMG and the DSO; he was many times mentioned in despatches and he was also awarded the Order of the White Eagle and the Order of the Nile.

On returning to England in July 1920 he reverted to his substantive rank of Lieut-Colonel and served as a CRE (Works) in London District and later at Warminster and at Codford, and finally as CRE 6 Division in Cork. In 1923 he was made Chief Engineer Gibraltar, his last appointment. He retired in 1926.

On retirement he went to live in Breconshire; he became a Deputy Lieutenant of the County in 1931 and Justice of the Peace in 1937.

He married in 1900 Kate Marjorie, daughter of Bowen Pottinger Woosman. They had two daughters. His wife died in 1941.

---

### BRIGADIER-GENERAL A. B. CAREY, CMG, DSO, OStJ

ARTHUR BASIL CAREY was the son of Colonel W. Carey, CB of the Royal Artillery. He was born on 3 March 1872 and educated at Sherborne and the Shop. He was commissioned into the Corps on 24 July 1891.

After completing his Chatham courses he served for two years in Malta before being posted to India in 1895 where he spent seven years with the Military Works Department at Peshawar, Gilgit and Secundrabad. While serving at Secundrabad he married Eva Mary, youngest daughter of E. S. Bradley Esq. On returning home in 1902 he was employed on special duties

at the School of Musketry, Hythe. In 1907 he was posted to a Works appointment at Middleburgh, Cape Colony, but in the following year he was sent to Canada for employment with the Canadian Forces at Halifax and Winnipeg.

He returned home shortly after the outbreak of the First World War and in 1915 he became CRE of the 63rd (Royal Naval) Division raised for service in the Dardanelles. The Royal Naval Division formed part of VIII Corps commanded by Lieut-General Sir Aylmer Hunter Weston. Carey's tasks included the construction and maintenance of the piers, quays and breakwaters built on the landing beaches on the Helles and Suvla fronts and during the final evacuation, when a great storm did an immense amount of damage, with a reinforced field company consisting of 600 men, he repaired and strengthened the damaged piers on West Beach thus enabling the last troops and their guns and equipment to be got safely away. For his outstanding work in the campaign he was mentioned in despatches and awarded the CMG.

After the withdrawal from Gallipoli and the breaking up of the Royal Naval Division Carey became CRE 5 Australian Division which was then in Egypt. He accompanied the Division to the Western Front in July 1916 and remained with the formation until November 1918, being awarded the DSO in 1917 for his gallant services. He was then made Chief Engineer VIII Corps British Armies in France and held that appointment until being posted home in January 1920.

On returning home he reverted to his substantive rank of Lieut-Colonel on taking up the appointment of CRE Forth Defences at Edinburgh. He did not, however, remain long in that post and the following year he was made Director of Military and Public Works, Mesopotamia. During the Arab Revolt of 1921 he became Chief Engineer of the Mesopotamia Expeditionary Force and he remained as Chief Engineer Iraq until April 1923 when he was posted home to become Chief Engineer, Scottish Command. He held that appointment until his retirement on 1 June 1927.

After his retirement he lived in Mexico City. He died on 29 March 1961, aged 89 years, after a long illness. He was, by special permission of the British Government, buried in the Mexico City Military Cemetery, the first military burial to be held there for forty years.

---

#### BRIGADIER L. MANTON, DSO, OBE

BRIGADIER LIONEL MANTON died on 23 July 1961 aged 74 years after a lifetime of service devoted to British military and civil railways at home and overseas.

He was born on 13 October 1887 the son of Adolf Fraustadt, and during the First World War his name was changed by deed poll to Manton. He was commissioned into the Corps from the RMA Woolwich on 20 December 1906. As a Second-Lieutenant at Chatham he was awarded the Fowke Memorial Medal. In 1909 he was posted to India and after a two years' tour in military works he joined 26 Railway Company at Sialkote, thus starting a long and outstanding connexion with railways. In October 1911 he was seconded for duty with the NW Railway, becoming Assistant Traffic Superintendent; two years later he was posted to a similar appointment with the East Bengal State Railways at Calcutta.



On the outbreak of the 1914/18 War he was at once recalled for military service and he joined the Indian Expeditionary Force in France as a Company Officer of 21 Company Royal Bombay Sappers and Miners shortly after the battle of Neuve Chapelle in which that Company had suffered very heavy casualties. In 1916 he was made an Assistant Director of Railway Transport in France and he held similar appointments until the end of the war and in the years immediately following it, becoming eventually Controller of Transportation France and Flanders. He was awarded the DSO in 1917 and the Belgian Order of the Crown; he was also twice mentioned in despatches.

He spent the year 1921 as an Instructor at the School of Military Administration at Chisleton, but in April 1922 he was made Assistant Director, General Transportation, British Army of the Rhine, and became a member of the inter-Allied Railway Commission in Cologne. He remained in that post for four years, being awarded in 1923 the OBE for his services.

In April 1926 he was posted home to become Staff Officer to the Chief Engineer Southern Command and from April 1929 until October 1930 he was DCRE Larkhill. He was then made Commandant of the Railway Training Centre, Longmoor, and he held that appointment until April 1935. After a short period on half pay he was posted to Egypt as Assistant Director Transportation with the rank of Colonel, but shortly afterwards he was appointed Chief Engineer, Malta. He retired on 9 December 1936.

After his retirement he became the Principal of the London Midland and Scottish Railway School of Transport at Derby and he held that appointment until the outbreak of the Second World War when he was recalled for service to become Commandant No 2 Railway Training Centre. He held that post from 1939 until 1941 and from October 1941 to June 1942 he was Director of Transportation in India with the rank of Brigadier. After the war he resumed the post of Principal of the School of Transport (Railway Executive) and he held that appointment until 1951.

His first wife Beatrice Louise, daughter of R. L. Ross, Esquire, whom he married in Bombay on 18 November 1910, died in 1920 leaving him two sons, one of whom was killed in action in 1943, and a daughter. On 18 June 1923 he married Joan, daughter of G. H. Gifford, Esquire, and had two sons.

Brigadier Manton was a frequent contributor to the *RE Journal* on Railway matters, and he helped to write the eight chapters in Volume V of the History of the Corps of Royal Engineers dealing with Transportation on the Western Front in the First World War. A road in the Transportation Centre RE, Longmoor, is named in his honour.

---

### BRIGADIER J. STUART

JAMES STUART, known to everyone as "Jug", was commissioned into the Corps in December 1919, and after his YO Courses at the SME he went to 26 Field Company at Aldershot.

He was posted to India in April 1924 and after six months with the Madras Sappers and Miners was transferred to the MES as GE Wellington. Eighteen months later he was appointed AGE Kohat and here began a period of continuous service of fourteen years in the North-West Frontier Province and Trans-Frontier Districts, first in the MES and subsequently in the PWD. After a year at Kohat he moved to Thall where he was responsible for

carrying out on his own the initial survey for the 40 miles of the Thall Idak trans-frontier road and for the preparation of the detailed planning of the Thall Spinwan Section.

He continued as GE in Thrall and Parachinar until he went back to England on leave in 1929. It was on the voyage out on his return from this leave that he first met Phyllis (Topsy) Hartnell, to whom he was subsequently married in July 1931. Soon after this he was promoted Captain. On his return from leave he spent a further four years in Kohat and Peshawar.

In 1939 it was decided to form a separate Civil PWD in the North-West Frontier Province to carry out the work which had previously been done on behalf of the PWD by the MES. Jug Stuart, with his considerable experience of the frontier districts, his ability to speak Pushtu and Urdu, and his intimate knowledge of Pathans, was an obvious choice for an appointment to this new organization. His first job was Personal Assistant to the Chief Engineer, who was also Secretary to the Provincial Government for that department and he, Jug, became involved in the administration of a department which was under the control of the Chief Minister of the Province at a time when political sensitivities were very touchy, to put it mildly. However, Jug was a tactful person, of broad vision and wide interests, and thus he was instrumental in establishing confidence in the minds of the rather untried NWFP politicians in the integrity and loyalty of the new PWD as a whole and of the Sappers in it in particular. His subsequent appointments were as Executive Engineer in the Malakand, Bannu and Hazara Divisions, all of which he ran with great ability. With the outbreak of the Second World War he was one of the early PWD Sappers to be recalled to military duty. This ended his service in the PWD, NWFP, as, though he was asked to return to the department after the war in the higher rank of Superintending Engineer, he preferred to continue serving in the Army.

During the war, he first started the very embryonic stores organization for the Expeditionary Force that was fitting out to go to Iraq, and he accompanied it to Baghdad in 1941. In 1943 he was appointed to the Engineer Resources organization in Delhi as full Colonel and was responsible for the creation and administration of the numerous depots all over India, which were responsible for feeding the Middle East, India itself and Burma.

After the war he did a spell of work in BAOR and the Control Commission, coming home to England to be Chief Engineer, South Western District in 1948 and subsequently being transferred as Chief Engineer to Catterick District and Northumbrian District.

After he retired he first took up pig farming near Exeter but this was not enough to satisfy his abilities. He, therefore, entered the world of civil engineering, first with the Mowlem organization in Persia and then as Project Manager for Costains in the Island of Gan in the Maldives. This was a big Air Ministry project for an airfield which had run into political trouble, but with Jug's experience he was able to deal with the local inhabitants in such a way that the project went forward to complete success. On leaving the Maldives, he went to Kharg Island, again for Costains, where he was appointed Group Construction Manager of a Consortium formed to undertake a £32 million project to construct a new oil terminal and ancillary buildings. This came to an end and he decided to take a trip round the East, Ceylon, Delhi, Persia, etc., and he returned to England only to die suddenly on 28 April last.

Jug was a gregarious, likeable and amusing character, and a very good amateur actor. He had a keen sense of humour which was not strained even when, on an overland journey by car from Britain to the NWFP, a case containing twenty Paris hats, bought there by his wife, Topsy (who was Norman Hartnell's sister), was stolen in Baghdad. Jug was merely intrigued as to the use that Arabs—with wives in strict purdah—could have for Paris hats, while travelling for miles on camels over endless deserts. It was suggested that, as in France where farm horses are sometimes provided with straw hats, the Arabs had put the Paris hats on their camels to protect them from the blistering desert sun. This suggestion delighted Jug and even consoled Topsy.

Jug was a very amusing and colourful character who always appeared to be completely idle, but anything he was running always succeeded. There can be no more fitting epitaph.

L.D.G.

---

### COLONEL J. HODGART, MC, TD

COLONEL JOHN HODGART, MC, TD, Honorary Colonel 102 Corps Engineer Regiment (TA), died on 6 April 1961 aged 69 years. He was the youngest son of the late Mr and Mrs John Hodgart, and he had a long and distinguished career in the Territorial Army. He served throughout the First World War in the Divisional Artillery of 51 (Highland) Division and he was awarded the Military Cross. In 1920 he transferred to the Royal Engineers and commanded the Divisional Engineers of the Highland Division from 1935 until 1938. During the Second World War, although not a young man, he commanded a Bomb Disposal Company RE which operated in London and the Home Counties from 1940 to 1945 throughout the German air offensive and later the flying bomb attacks. In 1959 he became Honorary Colonel of 102 Corps Engineer Regiment (TA) in all of whose activities he took the keenest personal interest. He was also the Honorary President of the Renfrewshire Branch of the British Legion. He was unmarried.

For many years he had been a Director of the engineering firm of Fullerton, Hodgart and Barclay Limited and he was a well-known resident of Meikleiggs and member of the Paisley Abbey congregation.

---

### COLONEL W. B. SYKES, CBE, TD, DL, JP

WALTER BURRANS SYKES died on 1 July 1961, aged 64 years. He was the son of the late H. B. Sykes Esq, of Huddersfield, and he graduated at Leeds University. He was a most ardent Territorial Royal Engineer and served throughout the Second World War in the Corps and on the General Staff in India, the Middle East, Italy and Yugoslavia. He remained an active member of the Territorial Army after the war, being promoted Colonel in 1951 and he retired from the TA Active List in 1957. In January 1952 he was appointed Honorary Colonel of 134 Corps Engineer Regiment (TA) and he held that appointment until he died. He was awarded the Territorial Decoration in



**Major GB Johnson OBE FRES**

1951 and the CBE in 1957. He served on the Council of the Institution of Royal Engineers and on its Finance and Membership Committee from 1948 to 1951 and from 1954 to 1957. In 1957 he was made a Deputy Lieutenant for the County of Essex; he was also a Justice of the Peace. He was a member of the Institution of Structural Engineers, of the French Society of Engineers.

In 1928 he married Francis Madge Davis of Droitwich. They had a son and a daughter.

---

#### LIEUT-COLONEL R. H. DENNISS

RAYMOND HANSON DENNISS was born on 21 August 1899. He was educated at St Paul's School and the Royal Military Academy, Woolwich, and commissioned into the Corps on 17 July 1917. After completing his Young Officer training he specialized in Survey and served in Jamaica and in India.

During the Second World War he was employed on survey work with the British Expeditionary Force in France, and after the withdrawal from Dunkirk he served in Iceland, Egypt and in Norway where he was decorated by King Haakon.

He retired from the Army on 1 October 1948 but he maintained a close link with the Corps through his employment with the Territorial and Auxiliary Forces Association at Edinburgh Castle and later with the Ordnance Survey where he was employed in their Scottish Regional office until July 1957. Lately, and until his death in Edinburgh on 19 April 1961, he worked with Charles Gray, architect on the technical and administrative side.

On 7 April 1931 he married Elizabeth Knecht at Le Crotois, Somme, France, and he is survived by his wife and only daughter.

---

#### MAJOR G. B. JOHNSON, OBE, FRES

GORDON BENNETT JOHNSON, who died at Eastbourne on 8 June 1961, was the son of the late J. W. Johnson of Belleville, Ontario, Canada. He was born at Belleville on 18 November 1880. On graduation from the Royal Military College, Kingston, he was commissioned into the Royal Engineers on 25 June 1900. After completing his YO studies at Chatham he served in Ceylon and in China. He went on the Regular Army Reserve of Officers on 26 August 1905 and later he joined the Canadian Foreign Service, being posted as Trade Commissioner to Japan.

He rejoined the Royal Engineers in 1914 and served in the Corps throughout the First World War rising to the rank of major. He returned to the Canadian Foreign Service after the war and became Trade Commissioner in Rio de Janeiro, Brazil.

In 1921 he was posted to Scotland as Canadian Government Commissioner with offices in Glasgow and he held that appointment until he retired on 18 November 1947. He was awarded the OBE in 1943.

On 31 December 1912 he married Anne Vaughan Amery of Ottawa. There were two sons of the marriage, both becoming soldiers, Lieut-Colonel G. B. A. Johnson and Captain M. W. Johnson of the Highland Light Infantry who predeceased him.

## Book Reviews

### THE STORY OF THE FRENCH FOREIGN LEGION

By EDGAR O'BALLANCE

(Published by Faber and Faber, Price 30s)

The fortunes of the French Foreign Legion are in eclipse today: generals are serving prison sentences, officers are in hiding or awaiting court martial, and at least one regiment is to be disbanded. All this is a result of their uprisings in Algeria; and it seems almost inconceivable when Major O'Ballance was writing *The Story of the French Foreign Legion* that there was no trace of the disease whose manifestations we have so recently witnessed. Yet we read on page 244 that "There can hardly be a corps in the world today in better heart". Your reviewer therefore feels that there is something fatally wrong in the Author's judgements, and that the book will not commend itself to the type of reader for whom—as the Preface tells us—it is mainly intended; namely, the military student.

Many facts, uncomplimentary to the Legion, are recorded, from which a different conclusion might be deduced. We read that "in an unguarded moment the French admitted that there had been some 2,000 Legion deserters" in 9 years of service in Indo-China; and that "perhaps double that number would be nearer the truth". This is a fact from which less favourable judgements might be made.

At Dien Bien Phu in 1953 the casualties amounted to 1,500 men killed, and over 4,000 wounded, "of whom over half were legionnaires". These are heavy casualties; but even so, the effect upon morale might not have been disastrous had the battle been successful. Indeed, by some strange paradox of human nature, the morale of the survivors might have been uplifted all the more, had there been a victory. But it was not a victory. In spite of supreme bravery and exertion it was an unnecessary defeat; and "nearly 9,000 were marched off into captivity with the wounded". Captivity raises no one's morale; it has the reverse effect. Moreover, the supreme French leadership was clearly at fault to lock up a mobile force to be besieged; and to misjudge the circumstances so badly that they lost them all. The days are past when soldiers were unable "to reason why". Soldiers today do reason why; and so far as your reviewer is aware the reasons for holding Dien Bien Phu were not good ones. The Author goes so far as to say (page 198) "the military foolishness of placing so many troops in such a position was obvious". No doubt it was obvious to the legionnaires too; and they could hardly be expected to be elated by the result. This sort of mismanagement is bound to reap a harvest of thistles.

In the most perfunctory acquaintance with the Foreign Legion in the Far and Middle East your reviewer was struck by the political whispering in the officers' messes and the bluebottle flies in the men's cookhouses. Conventional British military training suggested that these were outward signs of an inward ill; and the reader might feel that the Author, with his better opportunities for observation, ought to have discovered where the trouble lay, and should not have been overtaken by events. He might also, with advantage, have avoided some slipshod prose in many places. An example will be found on page 184.

In spite of the defects however—and there are many—the Author has certainly delved patiently into the past history of the Legion. He has contributed an interesting chapter (almost, as it were, an afterthought) entitled "A Few Facts about the Legion" in which he discusses Organization, Arms, Equipment, Officers, Men, Discipline, Morale, Ceremonial, Work, Deserters and Welfare "in that order". If the Author had been luckier in his judgements this might have been an outstanding book; but it has not turned out that way.

M.C.A.H.

# Technical Notes

## CIVIL ENGINEERING

Notes from *Civil Engineering and Public Works Review*, February 1961.

**"REINFORCED CONCRETE SPECIFICATIONS"**: A booklet on "Specification notes for Structural reinforced concrete in buildings" has been published by the Joint Committee on Structural Concrete (Cement and Concrete Association, Prestressed Concrete Development Group, Reinforced Concrete Association). Its purpose is to meet the need expressed by many architects and others for draft specification clauses for RC construction work in buildings.

**"INFLUENCE LINES FOR BENDING MOMENTS IN CONTINUOUS BEAMS AND PORTAL FRAMES"** by D. Binah, BSc (London) AMICE, MIHE: The article sets out to explain and illustrate a method by which influence lines for support and joint bending moments in continuous beams and portal frames can be rapidly determined. The method is claimed to yield particularly speedy results in the case of beams or of symmetrical frames of up to two spans. It may, however, be used to advantage with a larger number of spans, especially in symmetrical cases. The method is also applicable to unsymmetrical portals of one or more storeys or spans. The main feature of the method is that the same set of calculations simultaneously gives results for the influence values at all the supports, or joints of the structure, as the case may be.

Notes from *Civil Engineering and Public Works Review*, March 1961.

**"PRESTRESSED CONCRETE END-BLOCKS"**: A report entitled "An investigation of the Stress Distribution in the Anchorage Zones of Post-Tensioned Concrete Members" is available free of charge from the Cement and Concrete Association, 52 Grosvenor Gardens, London, SW1. It is concerned with the first stage in these investigations and deals with the problems of simple end-blocks.

**"THE USE OF ADHESIVES IN THE BONDING AND REPAIR OF PRECAST PRODUCTS,"** by M. Levy, PhD: The article, of which only Part I appears in the March 1961 edition, describes several applications of cold setting resins for the structural repair and jointing of precast concrete products. Resins such as the epoxy and polyester varieties are shown to have a bond and resin strength in excess of that of the concrete itself. They may be used for the repair of all types of products, pretensioned prestressed units excluded, which have become damaged due to accident or bad handling. Resins either in straight, or in extended, form may be used for mortaring the faces of beams in long line for post-tensioning operations.

Air-drying resins such as emulsifiable polyvinyl acetate are shown to have applications where bond and not resin strength greater than concrete strength is required, since they form very strong films.

**"THE PLASTIC BENDING OF BEAMS WITH REDUNDANT CONSTRAINT: BEAMS LOADED IN NON-PRINCIPAL PLANES,"** by A. Ormerod, BSc, DIC, AMI Mech E, of the Royal Military College of Science: The author of this article will be well known to all RE Officers who have passed through Shrivenham on degree courses since 1948. By considering experiments on angle sections as a simply-supported beam and a propped cantilever and analysing them, the author concludes that the simple theory of limit design may be used to estimate with fair accuracy the collapse load of a beam with redundant constraint, even when the loading is applied in a non-principal plane of the section.

"EFFECTS OF SEA WATER ON REINFORCED CONCRETE": The Sea Action Committee of the Institution of Civil Engineers has been investigating the deterioration of structures of timber, metal and concrete in sea-water since 1916. Their recently published Report, "The Durability of Reinforced Concrete in Sea-Water: National Building Studies, Research Paper No 30", is obtainable from HMSO price 4s. The Report concludes that the primary cause of deterioration of RC piles was corrosion of the reinforcement.

Notes from *Civil Engineering and Public Works Review*, April 1961.

"ENGINEERING DEVELOPMENTS IN THE USSR": These notes include some new ideas on the design of reinforced concrete retaining walls of 20 ft high and upwards. A relieving platform is built into the back of the wall at about a third of its height from the top. The earth pressure on this platform creates a stabilizing moment against the overturning moment caused by the earth pressure on the back of the wall. There is no bending moment in the wall except that induced by incidental loading. It is claimed that the new form of construction saves from 40 to 70 per cent over the traditional design.

"BEARING CAPACITY OF FROZEN RIVERS": The notes draw attention to a paper (NRC 5712) published by the Division of Building Research, National Research Council, Ottawa, on the bearing capacity of the ice of frozen rivers in Canada. The survey shows that ice thickness should never be taken as the sole criterion for the safe bearing capacity; the quality of the ice, the presence of cracks and the thermal history of the ice must all be considered.

"HIGH ALUMINA CEMENT CONCRETE, WITH DATA CONCERNING CONVERSION", by O. J. Masterman, B.Eng., AMICE, AMI Struct E.

This paper, which is meant to be read in conjunction with "BRS Digest No. 27", reviews the information available on the circumstances in which conversion can occur in concrete made with high alumina cement. It shows that fully converted aluminous cement concrete follows the well-known water-cement ratio law established for Portland cements and has substantial strength when mixes of low water cement ratio are used.

"A NOTE ON AERIAL PHOTOGRAPHIC INTERPRETATION", by M. D. Morris, F.ASCE.

The technique of Aerial Photographic Interpretation (API) using the stereoscope is already well known in the Army; these notes suggest ways in which it can be used to give the engineer useful technical information such as the determination of soil and geological formations, hydrological analyses, and the evaluation of trees in a forest. There are obvious limitations to the technique, which nevertheless has certain advantages to the engineer who can apply his existing knowledge to the interpretation of aerial photographs and thereby gain rapid and reliable information about extensive areas regardless of location.

Notes from *Civil Engineering and Public Works Review*, May 1961.

"LANDSLIDE INVESTIGATIONS IN RUSSIA", Part I, by H. R. Reynolds, AMICE.

Little information becomes available of civil engineering developments in Russia, and particularly scarce are details of technical investigations. However, information has recently become available on investigations into landslides, and Mr Reynolds' article reviews this information. The author considers first the Russian approach to the classification of slides, then gives detailed consideration to cracks and fissures in the slides, as this is a departure which is neglected in the British Isles in similar studies. Lastly, the author examines methods of measurement at surface and below ground level in Russia, by the provision of monuments and regular surveying operations. The Russian methods for studying slides appear to be simple and efficient and compare favourably with the methods generally adopted in this country and in America.



"PLASTIC COLLAPSE LOADS OF BEAM GRILLAGES", by M. Holmes, BSc, PhD, AMICE.

This paper describes tests carried out on about twenty model scale beam grillages and shows how the failing loads of the grillages may be calculated by the plastic method. The disparity between the calculated and experimental failing loads was generally less than 10 per cent.

"EXPERIMENTAL BLASTING STUDIES IN CANADA": A frequent problem associated with demolitions carried out in peace time in particular is the possibility of damage to nearby buildings, with the resulting claims associated with such demolitions. It is often difficult to prove that all these claims are legitimate, in the absence of reliable information about building damage known to result from blasting. An opportunity to gain such information arose when the St Lawrence Seaway-Power Project necessitated demolition of a large number of buildings in the area to be flooded. The Hydro-Electric Power Commission of Ontario and the National Research Council collaborated in a series of experimental blasting operations around some of these buildings. Results of the study have recently been published in a report which is available on application to the Publications Section, Division of Building Research, National Research Council, Ottawa, Canada

D.L.J.

### THE CONTRACT JOURNAL

Note from *The Contract Journal*, April 1961.

BS3318 "METHODS FOR LOCATING THE CENTRE OF GRAVITY OF HEAVY OBJECTS": The need for heavy objects (such as pieces of plant) to have their centre of gravity marked on them was demonstrated during ship-discharge operations at Christmas Island. Should the manufacturers omit these markings, the centre of gravity can be determined by the methods laid down in the BS, provided a weighbridge, pivoted inclined ramp or suitable crane hook are available. The BS is obtainable from the British Standards Institution, Sales Branch, 2 Park Street, London, W1, price 5s.

D.L.J.

### ENGINEERING JOURNAL OF CANADA

Notes from *The Engineering Journal of Canada*, March 1961.

TECHNICAL CONTROL OF READY MIXED CONCRETE: Recent years have seen many developments in concrete technology, and the control of concrete quality is now receiving increased attention by engineers. This paper does not deal with the basic requirements of materials, but is concerned primarily with practical methods of maintaining the standard of pre-mixed and transit-mixed concrete. Those likely to be concerned with large scale works employing weigh-batching and distribution from a central mixing plant will find in it a lot of interesting and eminently practical information, especially in relation to mixing time, retarders, and re-vibration. The author suggests explanations of the increase of strength gained by the use of retarders, and its enhancement by post-vibration, and he discusses the effect of air entrainment in low- and high-strength concrete respectively.

G. M. PIGGYBACK SYSTEM: This paper is of some general interest, as it describes the design and testing of a new type of goods container suitable for transport either by road or rail, and of the "matched" railway vehicle and loading system. Such equipment adds flexibility to rail distribution, and retains the economic advantages of rail movement between distant termini.

SILVER FALLS HYDRO-ELECTRIC PROJECT: The Silver Falls hydro-electric installation provides a typical example of the use of a hydraulic pressure tunnel to convey water from the intake to a power house and surge tank. Where both topography and rock quality are suitable, this method often has economic advantages over power canals and surface conduits, and it also affords security and freedom from climatic extremes. Uninterrupted construction work, reduced maintenance requirements, and the

preservation of existing surface features may be important considerations. Previous papers about this project, describing the organization of structural work, the driving and concreting of the two-mile tunnel, and the erection of the surge tank and penstock, have been summarized in the issues of the *RE Journal* for March and September, 1960.

This issue of *The Engineering Journal* contains two further papers dealing with this installation:

"*Tunnel and surge tank design*". Considerations affecting design are clearly set out, and the paper is both interesting and easy to read. The reasons for adopting certain construction techniques are also explained.

"*Concrete tunnel lining*". Practical work is clearly described in some detail, and good illustrations help in visualizing both the organization and the techniques adopted.

**ICE PREVENTION BY AIR BUBBLING:** In countries with severe winter temperatures, ice-formation on lakes and rivers introduces a number of engineering problems. Compressed air jets have, for some years, been used to bring "warm" sub-surface water to the surface by means of rising air bubbles, and this paper is designed to summarize the technical information at present available on the subject. As with the somewhat similar system which has been tried to reduce wave action at harbour entrances, it seems that considerable investigation is still needed before this technique can be efficiently developed.

Notes from *The Engineering Journal of Canada*, April 1961.

The first three papers in this issue are primarily of interest to specialists. The titles are: "High speed gearbox", "Planning of radio relay systems", and "Problèmes de Bactériologie dans la ventilation des salles d'opération". The latter, as its title indicates, assumes that the specialist concerned has a reasonable knowledge of French.

**HYDROLOGIC INVESTIGATIONS FOR THE SOUTH SASKATCHEWAN RIVER PROJECT:** A general description of this very large water conservation scheme was published in *The Engineering Journal* for May, 1960 (see *RE Journal*, September, 1960). This paper discusses the comprehensive preliminary studies carried out to determine the hydrological potential, and to estimate the requirements to be satisfied. It is upon these computations that project design is based. The last illustration gives an excellent bird's eye view of the over-all effect of full development.

**FIRE PROTECTION FOR ROTATING ELECTRICAL EQUIPMENT:** This discussion of a specialist subject is so logically set out, and so clearly written, that it is of considerable general interest to any engineer. It should certainly stimulate and clarify the thinking of those concerned with electric generators and motors.

**THE CRISIS IN MEASUREMENT:** This really amounts to a "scientific" plea for the universal acceptance of the metric system, about which much has recently been said and written. The argument that the die-hards should follow the example of Russia, Red China, Japan, and India will not have a world-wide appeal. Disadvantages, such as recurring decimals, are not mentioned.

**CONCRETE ARCH BRIDGE AT HARTLAND, NEW BRUNSWICK:** This graceful and imposing bridge, completed in 1960, is a series of seven reinforced concrete arches, with short approach spans at either end. The total span between arch abutments is 1,844 ft, and the road level is approximately 100 ft above average stream bed. The design has some unusual features, which are clearly brought out in this concise and interesting paper.

As the roadway rises throughout at a 1 per cent grade it was decided, for aesthetic reasons, to make the crowns of all arches follow the same grade, keeping the springing at the same horizontal level. Each arch is, however, cut from the same parabola, so that each has a different span, height, and height-to-span ratio. The spans increase consistently from 247 ft to 279 ft. The slender arch barrels are rigid, and the vertical projection of the arch thickness is constant at 3 ft 6 in. The decking is supported on reinforced concrete bents, spaced at approximately 20-ft centres.

In a completed structure of this nature, the resultant thrust on a pier is virtually a vertical force, but during construction unbalanced horizontal loads may be applied by the thrust of an arch from one side only. Two of the six piers in this bridge were specially designed to resist such loading, so as to simplify construction work. The importance of the design of falsework is clearly exemplified by an analysis of tenders submitted for the contract. The unit price of falsework clearly established the relationship of over-all quotations.

**TWO-WAY SLABS AND THEIR SUPPORTING BEAMS:** Despite the author's stated object, it is doubtful whether his paper will hold the attention of those who are not mathematically inclined.

Notes from *The Engineering Journal of Canada*, May 1961.

The four technical papers in this issue are not of great value to the military engineer, but their titles are sufficiently definite to attract those with particular interests. "*Engineering Review, 1960*" contains a wealth of statistical and factual information about Canadian achievements. The other titles are: "The behaviour of rarefied gases", "Effects of changing technology on labour and employment", and "Statistical quality control as a management tool".

R.P.A.D.L.

## THE MILITARY ENGINEER

JANUARY-FEBRUARY 1961

"Prestressed Structural Steel", by Charles C. Zollman. This article describes in considerable detail the principles, technical methods and testing systems involved in the use of shallow depth beams as load carrying members in buildings and bridges by a process of manufacture known as the preflexing technique. This consists in encasing the tension flange of a steel beam in high quality concrete after the bare steel beam has been temporarily loaded. The article is illustrated with photographs of bridges and structures using this method and also with diagrams. There is also an account of laboratory tests being carried out in the United States.

"The Civil War Centennial, 1961", by Major-General Ulysses S. Grant 3rd, United States Army, retd. This article and the three which follow it, "Military Railroad Construction Corps", "Confederate Engineer Odd Jobs" and "Fredericksburg 1862" are chiefly interesting because they show how the military engineers engaged on both sides in the Civil War were the first to employ what can be called modern engineer methods and equipment in the service of the armies. Of particular interest is the use of the railways and the engineer and staff organization for their use, operation, and maintenance, which were very much the same as during the last war. It is a little unexpected to read of barbed wire entanglements, land mines, and booby traps. The pontoon bridge equipment developed then remained standard until 1918.

"Military Engineering 1961. Nuclear Combat, Missiles, Space", by Major-General S. R. Hanmer, U.S. Army. The Engineer Corps is engaged on several projects under the above headings and the basic features of some of them are summarized here. For tactical mobility on the nuclear battlefield a Standard Universal Tractor with Dozer has been designed to be the squad truck in Engineer units. A photograph is given. Other projects include a nuclear power train with cross-country performance, and small transportable power units to produce high pressure air, heating, and air conditioning for missile firing. The Corps is also engaged on a study of the problems of construction on the moon. The uses of satellites in geodetic work is also briefly described.

"Oxidation Ponds for Sewage Treatment", by Colonel Ernest W. Steel, U.S. Army, retd. A description of a method of sewage treatment which has distinct advantages for the military engineer when quick results are needed and where there is plenty of room.

"New Military Equipment", by John E. Quaile. The equipment described includes a new sea-going hopper dredger, a method of transferring vehicles at sea from one vessel to another, a shelter made of plastic foam, a recoilless rifle and an anti-tank missile.

"25 Years of Soil Cement Paving", by E. G. Robins and L. T. Norling. A short history of the increasing use of soil cement paving in the USA in war and peace with an account of the lines on which research is being carried out today.

"Isotopic Power", by Jerome G. Morse. The development of small electric generators using the heat produced when the particulate or electromagnetic radiations emitted by sealed radioisotopes are absorbed in the surrounding containment material is receiving active attention in the US and this article describes the principles involved with details of generators in operation and under development. Such generators are particularly valuable for use in satellites and space ships and for many terrestrial power requirements, as for instance, radio beacons, navigational buoys, deep-sea oceanographic investigations and many others. In fact for any purpose where a low-powered generator is required to operate for long periods without attention.

To avoid a difficult shielding problem the isotopes used in the generators described are alpha emitters Polonium 210 and Strontium 90. The conversion of the heat produced into electricity is thermoelectric. There are good illustrations and the design and operation of the units is described in considerable detail.

"Design of Guyed Towers", by Lieut-Colonel Robert S. Rowe, United States Army Reserve. A full detail of the methods of calculation and design of guyed towers with charts and photographs.

#### MARCH-APRIL 1961

"Space Report 1961", by Donald L. Meyers. The author is chief of the Engineering Division at the Rock Island Arsenal where his work includes development for production of rocket and guided missile launchers. In this article he surveys the history of space exploration to date and describes possible future developments. Of particular interest is the account of the progress made in the design of an ion motor on the thermoionic principle which may provide the propulsion power needed for extensive journeys in space. Tables giving details of rocket boosters, satellites and space probes with illustrations and a full record of all successful launchings both US and USSR up to January 1961 are very valuable for reference.

"Space Missile Facilities", by Colonel Paul D. Troxler, United States Army, ret'd. An account of the growth of the missile launching centre at Cape Canaveral. A summary of the great variety of the facilities provided is given. The article is of great interest, is well illustrated and shows what an immense effort goes into providing the means of launching and recording apart from the design and construction of the missile itself.

"Engineer Problems of a Lunar Exploration", Second-Lieutenant Clyde M. Reedy, Corps of Engineers. That the difficulties imposed by the special physical conditions obtaining on the moon can be overcome is the theme of this article which states the problems to be solved and indicates the lines on which solutions may be found. In a comment Major Ira Hunt, Corps of Engineers, describes a proposed 10-metre diameter stainless steel research chamber in which the lunar environmental features of pressure, solar radiation, and temperature would be simulated. In such a chamber the engineer would be able to identify and perhaps solve many of the problems of lunar construction.

"Combat Engineers 8—Attack and Setback at Cambrai", by Kenneth J. Deacon. The first American casualties in the 1914-18 war were two men wounded by shell fire while working with their unit the 11th Engineers on the rehabilitation of the railway line from Epéhy to Gouzeaucourt in preparation for the battle of Cambrai. The 11th Engineers completed the railway to Marcoung during the first successful

phase of the battle and fought as infantry under the 20th British Division during the fighting that followed the German counter attack.

"Base Construction for Bomarc", by John M. Norvell. Bomarc is the Air Force supersonic missile for area defence. It is an unmanned interceptor for the destruction of enemy high flying bombers. This article gives some information on the performance of the missile and of the location and design of the bases and the installations thereon. There are some good photographs. It does not say whether Bomarc is effective against inter-continental ballistic missiles.

"The Armoured Division—A combined Arms Team", by Major John C. Burney Armor. A full clear description of the composition, organization and command system of an American Armoured Division. There are good photographs of the various types of armoured vehicle and bridging equipment.

#### MAY-JUNE 1961

"A Design for Transportation Progress", by Ernest A. Herzog. This well illustrated article states the case for the monorail as the best solution for most big city transportation problems. The illustrations show how much development has been completed in this field. A double track monorail is to be constructed in the city of Seattle for the Century 21 Exposition. The track will be about one mile long and is scheduled to be completed in ninety days and is expected to carry between 60,000 and 90,000 passengers daily during the course of the Exposition.

"Aerospace Propulsion", by Brigadier-General Irving L. Branch. The Aircraft Nuclear Propulsion Office (ANPO) created by the Department of Defence and the Atomic Energy Commission is working on a schedule to culminate in nuclear flight in the mid-1960s. This article describes the main features of the programme and refers to several reactor devices of the type described in the article on Isotopic Power in the January-February 1961 number. Although the urgency and large scale of the work is made clear there is little technical information.

"Power for Payloads in Space", by Colonel James E. Harper, Corps of Engineers. This is another article dealing with the problems of space travel. The isotopic reactors described in the article on Isotopic Power in the January-February number are mentioned and other types also under development. There is a description of methods of using solar power. The second part discusses how to provide power for propulsion. There are projects in hand for studying ion propulsion devices, nuclear rockets and electromagnetic systems. Brief notes on their characteristics are given.

#### MILITARY ENGINEER FIELD NOTES

There is an interesting account of the Polecat Tractor which has been developed for the transportation of personnel and stores in Polar regions.

"War Logistics in the Atomic Age", by Captain R. R. Campbell, Supply Corps United States Navy. The whole field of Atomic Age Logistics is covered in this well-thought-out article which gives much interesting information on the way in which the United States armed forces are thinking about, and tackling the problems involved.

"Construction Planning for Greenland", by E. H. Vaughan, Jr. A short illustrated article on the organization of construction work in Greenland.

"Amphibious River Crossings", by Lieut-Colonel Delbert M. Fowler, Corps of Engineers. This is a brief account of a training exercise in Germany but it includes very full tables giving the characteristics and specifications of the French fully mobile amphibious class 100 bridge units and class 20 raft units.

"Mobility Through a River Line", by Colonel John D. Cole, Corps of Engineers. Another description of the French "Pont Amphibe" with comments and a comparison with the American version which has been developed from French ideas for manufacture in the United States.

J.S.W.S.



BY APPOINTMENT TO HER MAJESTY THE QUEEN  
GOLDSMITHS & CROWN JEWELLERS,  
GARRARD & CO. LTD., LONDON

## GARRARD OF REGENT STREET

Along the graceful curve of Regent Street stands the House of Garrard, where the finest examples of modern and traditional jewellery, silverware and watches are to be found.

The tradition of Garrard has been built up over more than 200 years: our designers and craftsmen create exquisite pieces, simple or elaborate, according to your taste. For the discerning people who buy from Garrard, only the best is selected.

Our military department specialises in making presentation plate, mess plate, cups and other trophies: these may be to your own design, from a picture or sketch, or we can produce designs to suit your requirements. We have also the badges of most corps and regiments, in miniature, beautifully fashioned in gold and enamel or set with diamonds.

Catalogues are available under the following titles: "Silverware", "Regent Plate", "Mess Plate", "Watches" and "Gifts". Tax free export price lists are also supplied upon request.

*A recent silver statuette created by Garrard in exact detail from life.*



## GARRARD *Crown Jewellers*

112 REGENT STREET, W.1. Tel: Regent 3021 (11 lines)

A **VICKERS** Onions scraper  
behind any Crawler tractor  
gets through the job faster

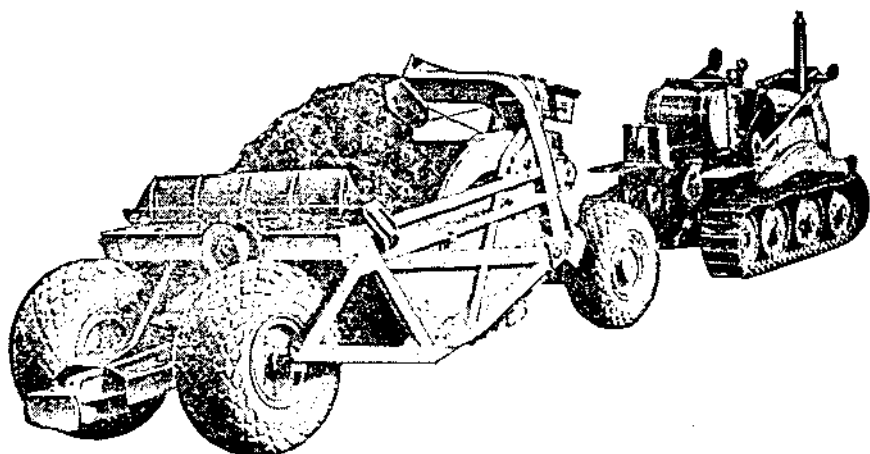

Here are **7** reasons why:

1. Onions have achieved Open Bowl design without the usual increase in overall width on cutting edge width.
2. The balanced draw bar enables scraper to be coupled to tractor by one man. It is perfectly safe and will not go over centre.
3. Sidecutters are fitted for peak efficiency in hard going.
4. Although Onions scrapers are robustly built their extremely low deadweight allows you to get the most out of your tractor.
5. The low bowl gives greater stability on all terrains.
6. There is an Onions scraper for every crawler tractor.
7. A wide range of other equipment including Control Units, Compaction Rollers, Rippers, etc., can be provided.

**VICKERS - ARMSTRONGS (ONIONS) LTD.**

ONIONS WORKS, BILSTON, STAFFS      •      Tel: BILSTON 41751/5

Dealers in Great Britain: Jack Olding & Company Limited · Hatfield · Herts · HATFIELD 2333  
SCOTLAND: Jack Olding & Co. (Scotland) Ltd., Coupar Angus, Perthshire · COUPAR ANGUS 281

# J. M. HILL

& SONS LTD.

BUILDERS & CONTRACTORS  
TO  
WAR OFFICE • AIR MINISTRY  
MINISTRY OF WORKS • L.C.C.

WEMBLEY

7781



BY APPOINTMENT  
TO HER MAJESTY THE QUEEN  
HATTERS

*Herbert Johnson*  
(BOND STREET) LTD.



**REGIMENTAL  
CAPMAKERS TO**

**ROYAL  
ENGINEERS**

**HERBERT JOHNSON**  
*specialise in hats for every  
occasion — faultless hats  
made to suit you personally,  
with the same distinctive  
correctness that is observed  
in the making of all  
regimental headgear. Also  
available are impeccable  
accessories including  
regimental and club ties.*

38 New Bond St., London W.1.  
Mayfair 0784  
Weekdays 9 a.m. — 5 p.m.  
(Thursdays 6.30 p.m.)  
Saturdays 9 a.m. — 1 p.m.  
40a London Rd., Camberley  
(Wednesday afternoons only)



# NAAFI 1921-1961

Forty Years of Service  
to the Services

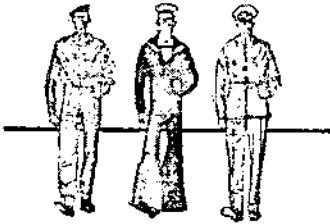

## Credit Sales Soar

The phenomenal success of the instalment credit sales scheme introduced by Naafi in November, 1959, is telling proof of the extent to which it is appreciated by men and women of the Services. And no wonder. Highly favourable terms make it possible for them to buy from a vast range of household and personal goods without the need of ready cash.

The scheme is open to all officers and other ranks over the age of 17½ years. Units and messes may

also take advantage of it. Dividend or discount is payable on the majority of items and the maximum credit charge is only a penny in the pound each month. Payments may be made weekly, fortnightly or monthly. There is no problem about postings; an agreement signed in the United Kingdom can be transferred to any Naafi shop anywhere. Ask your shop manager for details.

IMPERIAL COURT, KENNINGTON LANE, LONDON, S.E.11.

*H.M. Forces' Official Trading Organisation*

## HISTORY OF THE CORPS OF ROYAL ENGINEERS

Volumes of this History, covering the period 1066 to 1948, are on sale from the Institution of Royal Engineers, Chatham, at the following rates:—

Volumes I to VII ordered together—price £2 10s. to members, or £10 to non-members.

Volumes IV to VII ordered together—price £1 10s. to members, or £6 to non-members.

Volumes I to VII—10s. each to members of the Institution or 35s. to non-members.

Volumes VIII and IX—15s. each to members of the Institution, or £2 7s. 6d. each to non-members.

For well over half a century Cleveland engineers and craftsmen have been engaged in the construction of almost every type of large structural undertaking. Bridges, dock gates, aircraft hangars, landing stages, tunnels, pontoons, barges, pylons. Perhaps the greatest tribute to the versatility of Cleveland (and its customers) is that, even after seven decades, seldom a month passes without a call to tackle something new.

## structural steelwork by **CLEVELAND**

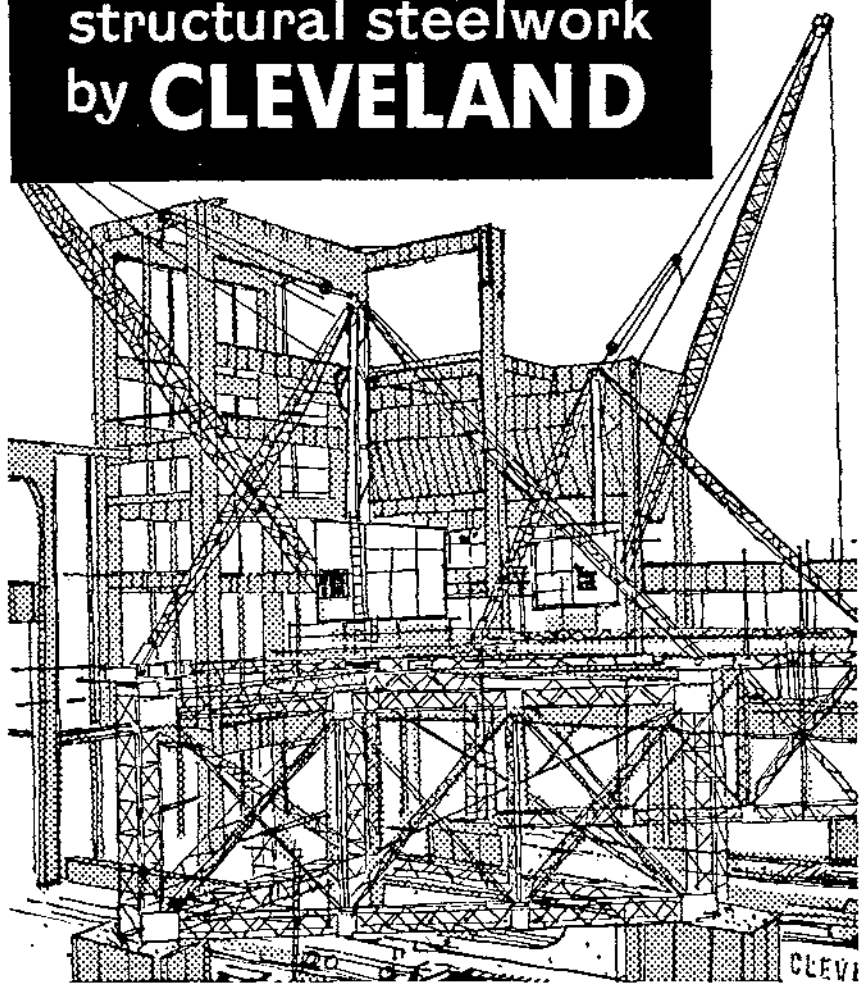

**THE CLEVELAND BRIDGE & ENGINEERING CO. LTD., DARLINGTON, ENGLAND**

---

---

G. PERCY

# TRENTHAM

LIMITED

BUILDING

AND

CIVIL ENGINEERING

CONTRACTORS

BIRMINGHAM      READING

LONDON      GLOUCESTER

STOKE-ON-TRENT      CARDIFF

WOOD LANE BROMFORD BIRMINGHAM  
PANGBOURNE READING BERKS  
NEW ROAD RAINHAM ESSEX  
UPTON LANE BARNWOOD GLOUCESTER  
PARK HALL LONGTON STOKE-ON-TRENT  
ROATH BASIN BUTE DOCK CARDIFF

Erdington      2491  
Pangbourne      411  
Rainham      2902  
Gloucester      66172  
Stoke-on-Trent 39147  
Cardiff      30256

---

---



★ ★ ★ ★ ★  
**FIVE STAR  
MOTORING**

To people going overseas who are considering buying a new car:  
To officers proceeding abroad, serving overseas or returning to  
this country for leave:—

We can offer any of the Ford range of cars Free of Purchase Tax,  
subject to currency and import restrictions in certain territories.  
These cars may be used in the United Kingdom for six months  
prior to exportation. We shall be pleased to send full details on  
request.

## **BROOK GARAGE**

(CHATHAM) LTD.

Phone 41141

**315 HIGH STREET, CHATHAM, KENT**

MAIN FORD DISTRIBUTORS

POPULAR ANGLIA : PREFECT : CONSUL : ZEPHYR : ZODIAC

---

The printers of this journal

---

**MACKAYS OF CHATHAM**

---

are at your service for printing, bookbinding and blockmaking

---

W. & J. MACKAY & CO LTD FAIR ROW CHATHAM

TELEPHONE CHATHAM 42243-5